

We support PV systems

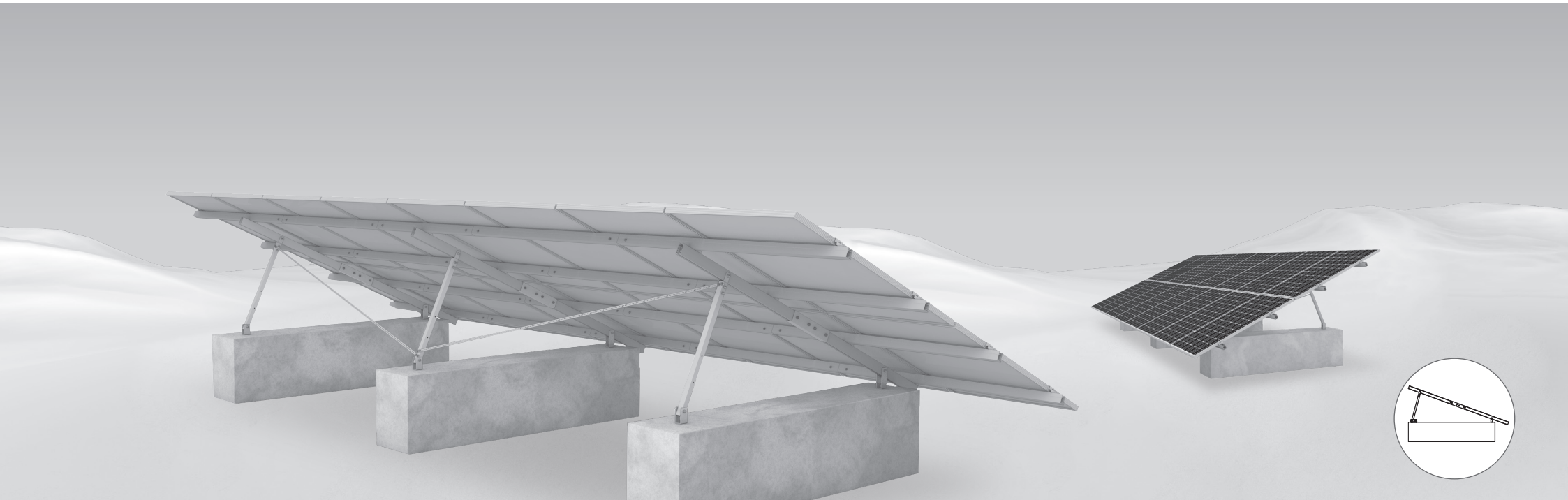

A-Rack System

ASSEMBLY INSTRUCTIONS



General safety information

Please note that our general mounting instructions must be followed at all times and can be viewed online at k2-systems.com/en/technical-information

- The equipment may only be installed and operated by qualified and adequately trained installers.
- Prior to installation, ensure that the product complies with on-site static loading requirements. For roof-mounted systems, the roof load-bearing capacity must always be checked.
- National and local building regulations and environmental requirements must be adhered to.
- Compliance with health and safety regulations, accident prevention guidelines and applicable standards is required.
 - Protective equipment such as safety helmet, boots and gloves must be worn.
 - Roofing works must be in accordance with roofing regulations utilising fall protection safeguards when eaves height exceeds 3 m.
 - At least two people must be present for the duration of the installation work in order to provide rapid assistance in the event of an emergency.
- K2 mounting systems are continuously developed and improved and the installation process may thereby change

at any time. Prior to installation consult our website at www.k2-systems.com/en/technical-information for up-to-date instructions. We can send you the latest version on request.

- The assembly instructions of the module manufacturer must be adhered to.
- Equipotential bonding/grounding/earthing between individual parts is to be performed according to country specific standards, as well as national laws and regulations.
- At least one copy of the assembly instructions should be available on site throughout the duration of the installation.
- Failure to adhere to our general safety and assembly instructions and not using all system components, K2 is not liable for any resulting defects or damages. We do not accept liability for any damage resulting in the use of competitor's parts. Warranty is excluded in such cases.
- German law shall apply excluding the UN Convention on CISG. Place of venue is Stuttgart. Our General Terms of Business apply.
- If all safety instructions are adhered to and the system is correctly installed, there is a product warranty entitlement

of 12 years! We strongly recommend reviewing our terms of guarantee, which can be viewed at www.k2-systems.com/en/technical-information. We will also send this information on request.

- Dismantling of the system is performed in reverse order to the assembly.
- K2 stainless steel components are available in different corrosion resistance classes. Each structure or component must be carefully checked for possible corrosion exposure.

The following guidelines apply

The A-Rack system can be used without further testing by K2 Systems in the following standard conditions. The system is also suitable for higher requirements. However, if a value exceeds the standard conditions, please contact K2 Systems.

Ground requirements

The following soil properties were assumed:

- $\phi = 25^\circ$ [slide friction angle]
- $\sigma_{R,d} = 130 \text{ kN/m}^2$ [soil pressure resistance]
- $\gamma = 16 \text{ kN/m}^3$ [unit weight earth-moist]
- $\gamma_a = 6 \text{ kN/m}^3$ [unit weight below groundwater table]

A sufficient capacity of the soil needs to be checked in the specific project by the constructor/owner of the site.

Structural requirements

Module quantity	Module sizes		Permissible loads	
	Length [mm]	Width [mm]	Set 2002717	Set 2002780
16	1580 - 1650	980 - 1005	0.80 kN/m ²	1.30 kN/m ²
14	1580 - 1785	980 - 1060	0.80 kN/m ²	1.30 kN/m ²
14	1722 - 1785	1060 - 1150	S ₁	S ₂

For module widths between 1060 mm and 1150 mm, the maximum possible loads are reduced proportionally to the increase in module area.

If, for example, a module with the dimensions 1722 × 1134 mm with Set 2002717 [initial load limit 0,8 kN/m²] is to be used, the max. permissible wind and snow load is calculated as follows:

- Permissible load = $[1 - (14 \times 1.722 \times 1.134 / 26.532 \text{ m}^2 - 1)] \times 0.8$
Permissible load $\approx 0.77 \text{ kN/m}^2$

Formula for calculating the permissible loads:

- Permissible load $S_1 = [1 - (14 \times \text{Module Area in m}^2 / 26.532 \text{ m}^2 - 1)] \times 0.8$
- Permissible load $S_2 = [1 - (14 \times \text{Module Area in m}^2 / 26.532 \text{ m}^2 - 1)] \times 1.3$

Important mounting instructions

- On-site general standards and regulations for lightning protection must be observed and consultation with a specialist to create a lightning protection concept is recommended [use lightning protection clamp if necessary].
- Adhere to module manufacturer recommendations for clamping area and module installation [see module manufacturer instructions].
- Tightening torque
 - M8 screws: 14 Nm
 - M10 screws: 30 Nm
 - Multi Monti: 90 Nm
- Module frame heights: 30 - 42 mm [other module clamps available]

Tools

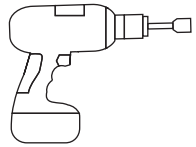

8/17/21 mm

8 mm

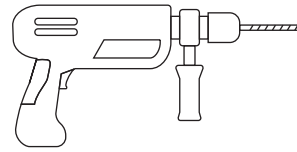

Ø 12 mm
L ≥ 120 mm



10 - 100 Nm
(7.4 - 73.8 lb-ft)



8/17/21 mm

8 mm

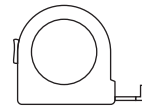

≥ 3.0 m



≥ 6.0 m

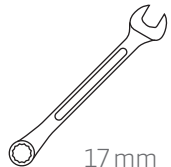

17 mm

Components

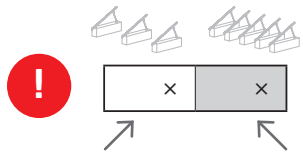

Set 2002717 **Set 2002780**
 3× support 5× support
 0.8 kN/m² 1.3 kN/m²

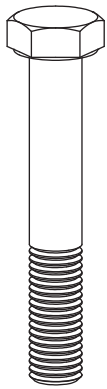

2002410
 Hexagon bolt
 M10×60

27× 45×

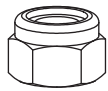

1002849
 Self-locking
 hexagon nut M10

27× 45×

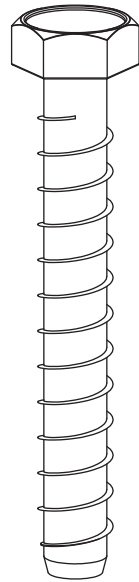

2002627
 Multi Monti
 14×110

6× 10×

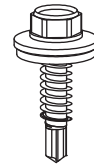

1001051
 Self-tapping screw
 5.5×25

40× 42×

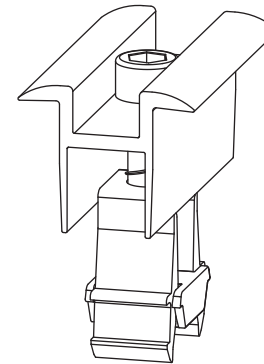

2004146 / 2004148
 K2 Clamp MC
 25 - 40 mm
 silver / black

28× 28×

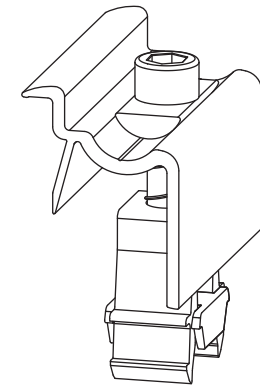

2003451 / 2003452
 K2 Clamp EC
 30 - 40, Hybrid
 silver / black

8× 8×

2003071 / 2003072
 OneMid
 30 - 42 mm
 silver / black

2002514 / 2002589
 OneEnd
 30 - 42 mm
 silver / black

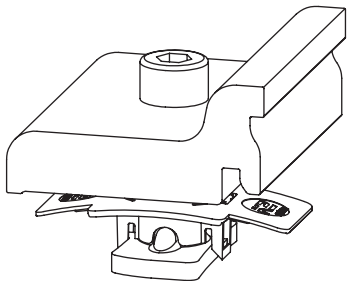

2001626
 Climber 63 Set

12× 20×

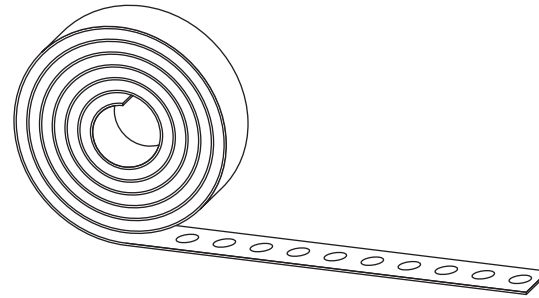

2002735
 Perforated tape

10m 10m

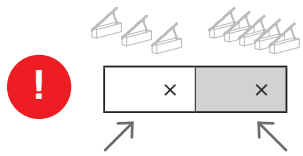

Set 2002717 **Set 2002780**
 3× support 5× support
 0.8 kN/m² 1.3 kN/m²

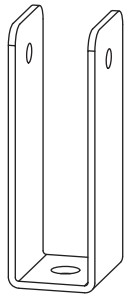

2002582
Foot Front

3×	5×
----	----

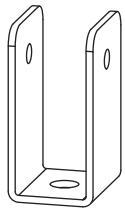

2002583
Foot End

3×	5×
----	----



2002599
Connector
Cross-Tie

6×	10×
----	-----

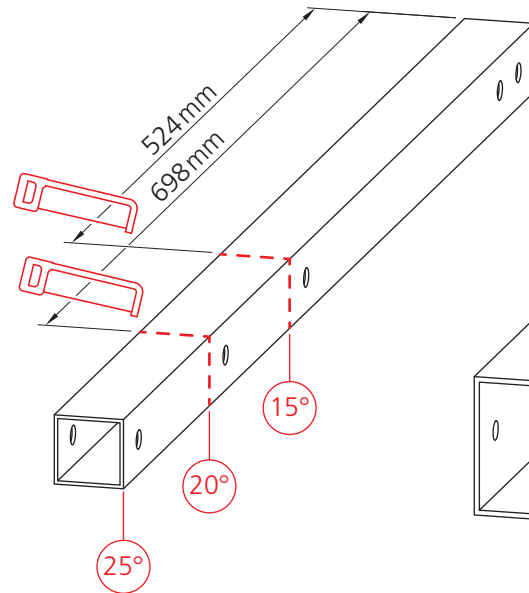

2002602
Cross-Tie
 · 25° no sawing
 · 20° sawing at 698 mm
 · 15° sawing at 524 mm

3×	5×
----	----

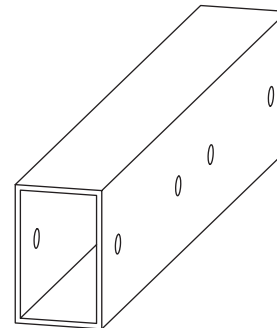

2002516
Rail Connector
CrossBar 3.0

3×	5×
----	----

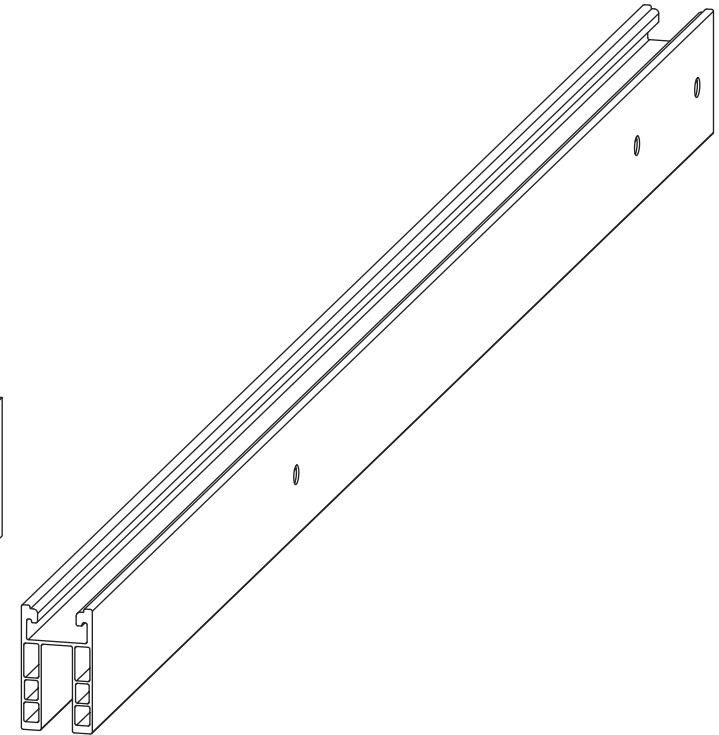

2002584
CrossBar 3.0

6×	10×
----	-----

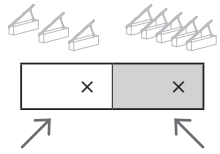

Set 2002717 **Set 2002780**
 3× support 5× support
 0.8 kN/m² 1.3 kN/m²

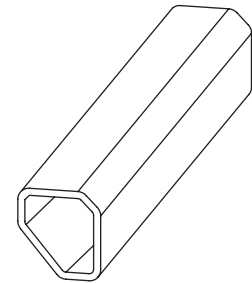
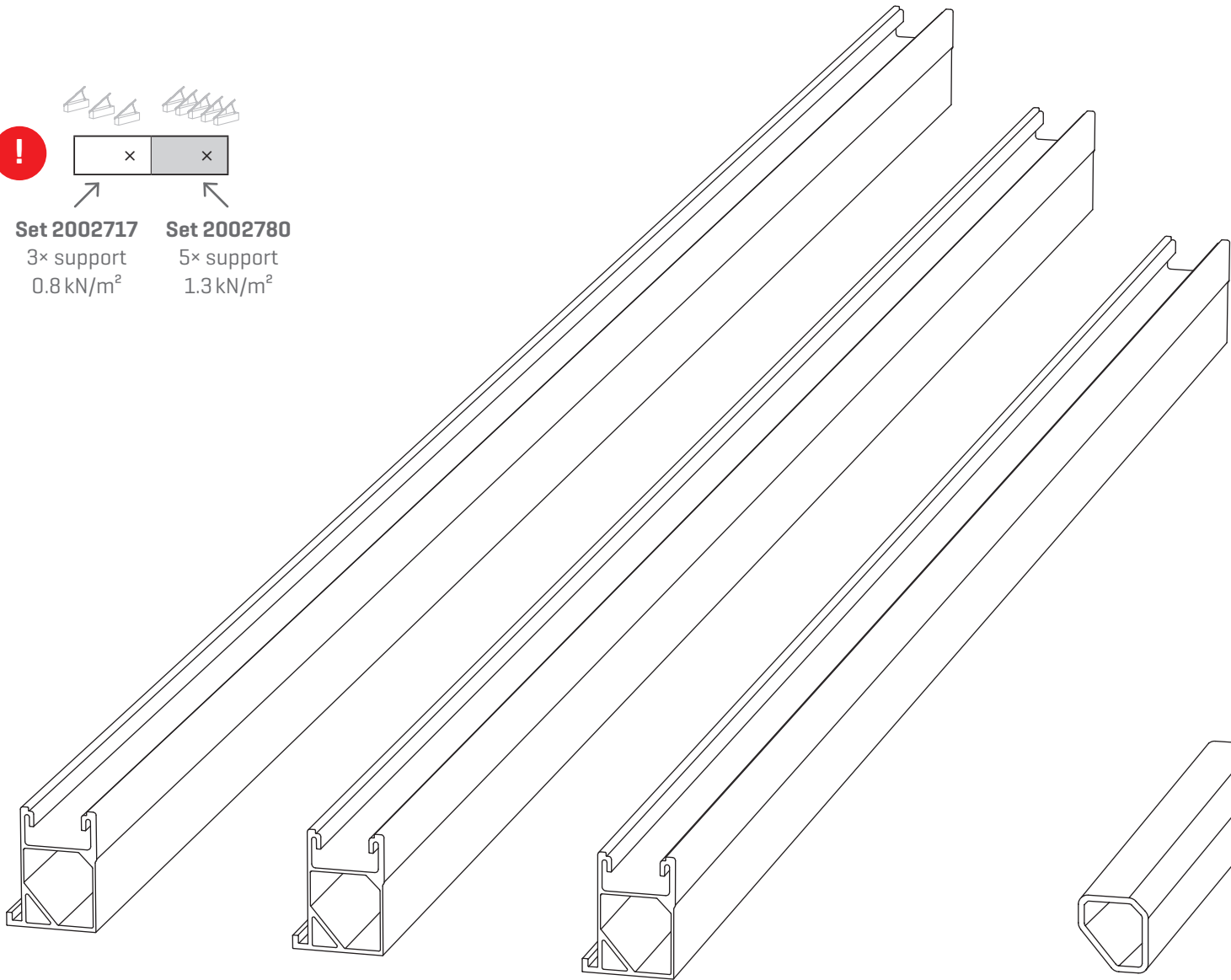

2002580 / 2002784

SingleRail 63;
 1.90 / 2.0 m

8× 8×

2002579 / 2002785

SingleRail 63;
 1.60 / 1.72 m

8× 8×

2002578 / 2002786

SingleRail 63;
 1.30 / 0.87 m

4× 4×

2001297

Rail Connector
 SingleRail 63

16× 16×

Assembly

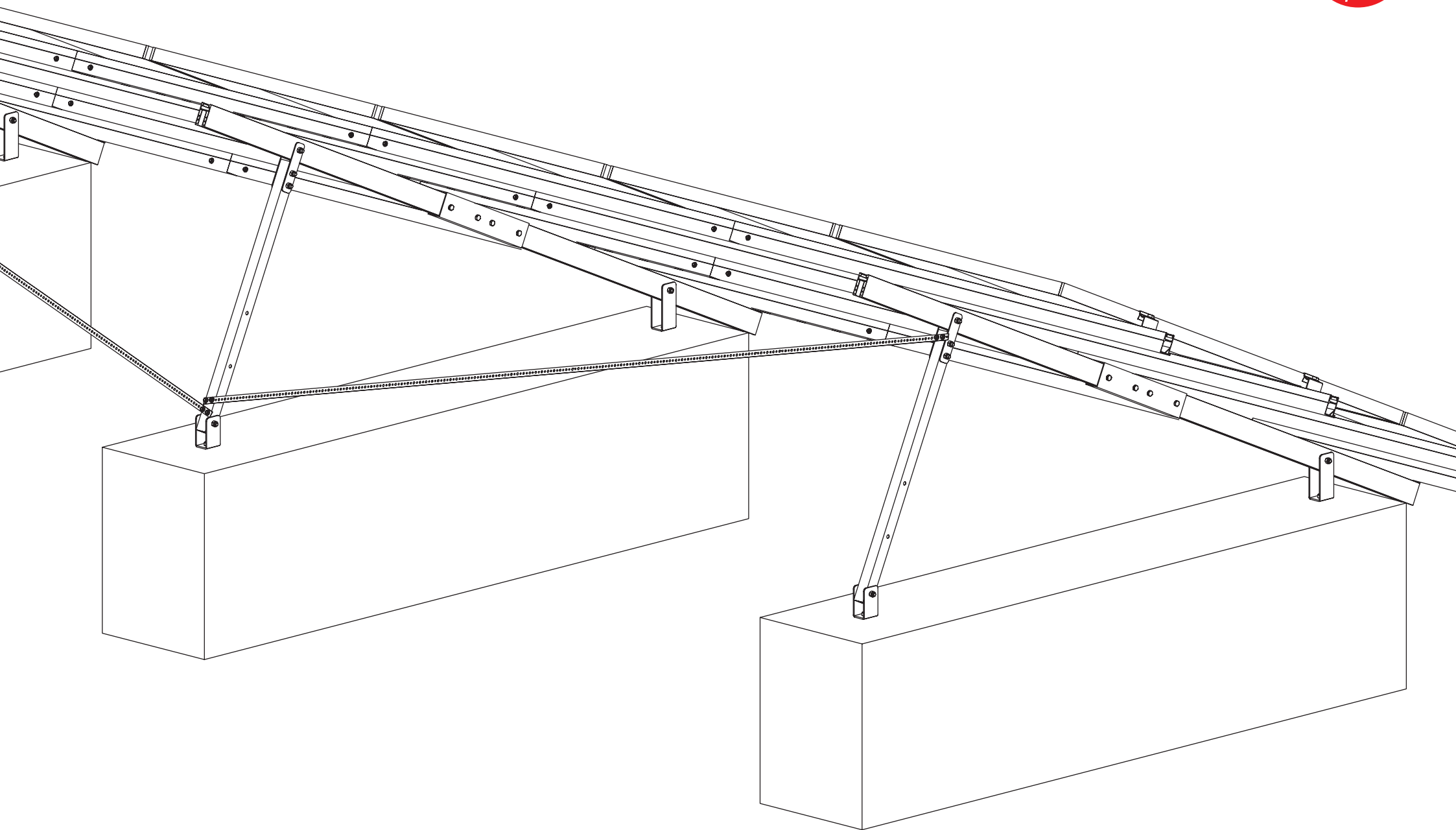

1

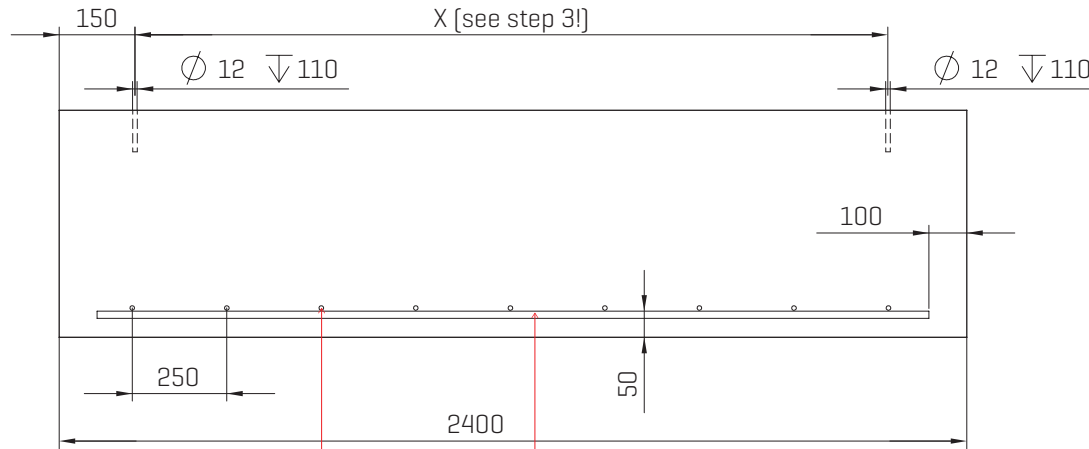
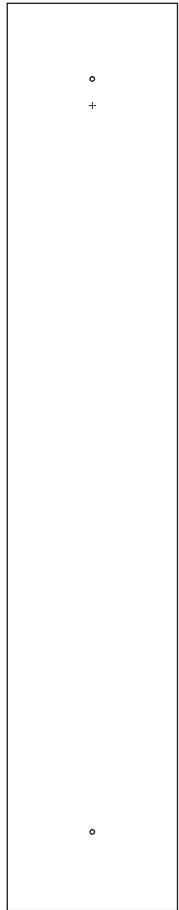
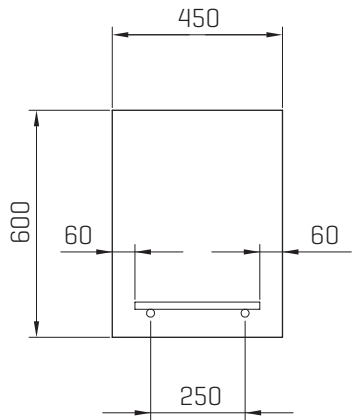

2 $2 \times \varnothing 12 e=25$

1 $9 \times \varnothing 12 e=25$

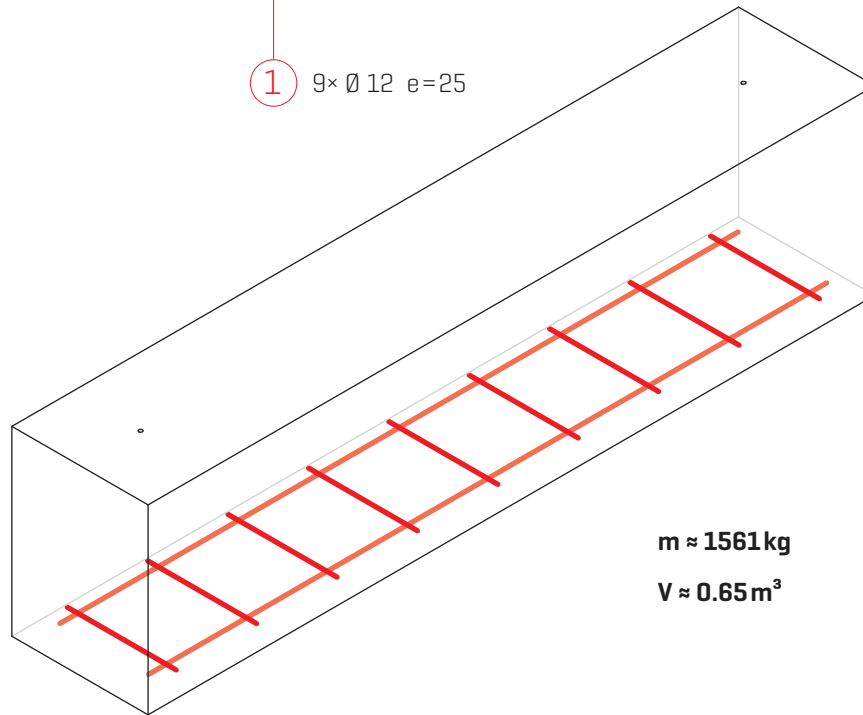

$m \approx 1561 \text{ kg}$
 $V \approx 0.65 \text{ m}^3$



Dimensions in millimetre [mm]!

Construction steel EN10025

Position	Amount	\varnothing	Length
1	9	12	0.33m
2	2	12	2.20m

$\Sigma = 7.37 \text{ m [6.55 kg]}$

2

A 3× support · 0.8 kN/m² wind/snow load

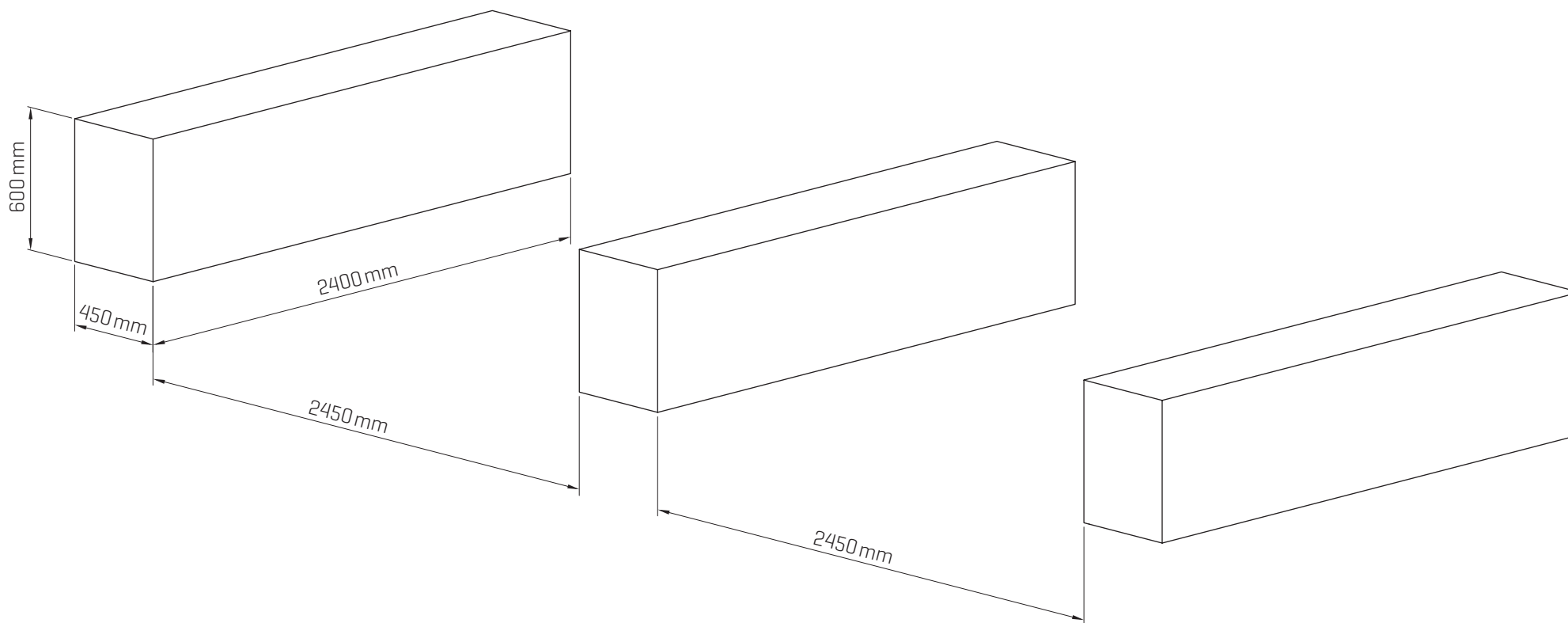

2

B 5× support · 1.3 kN/m² wind/snow load

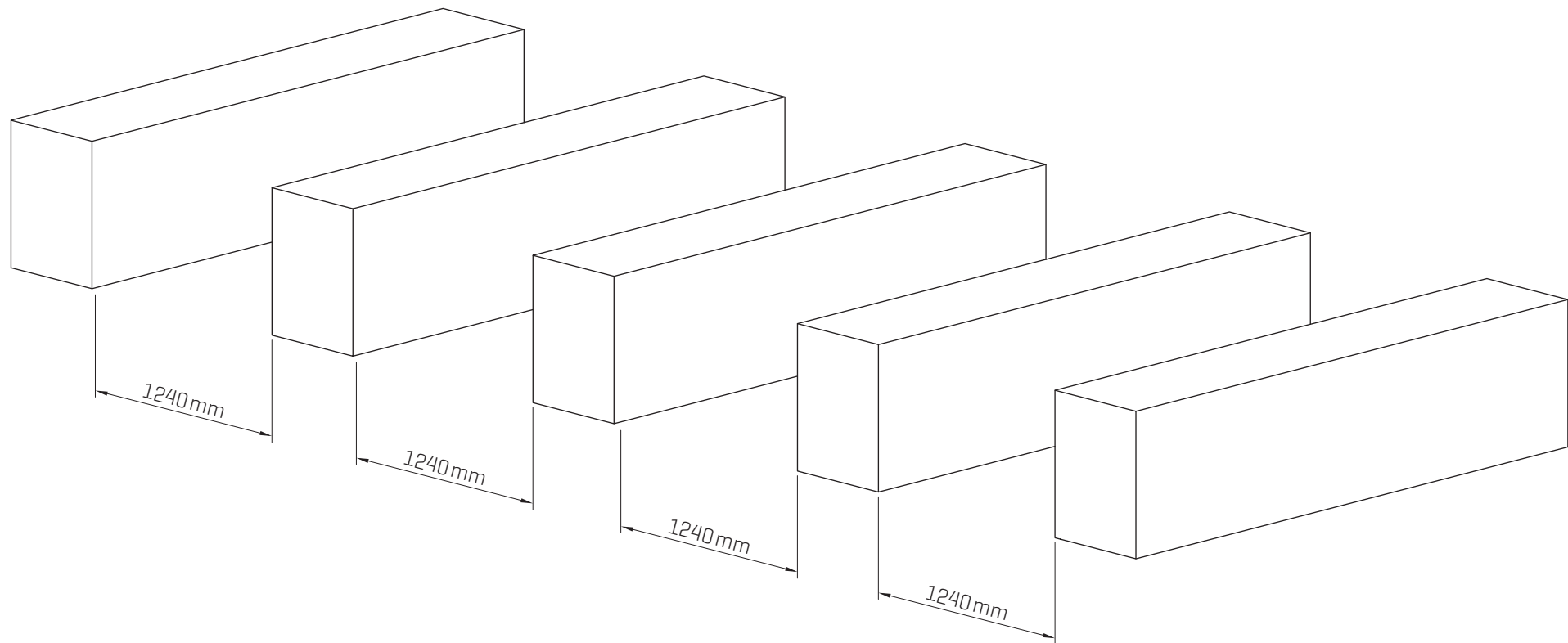

3

A 3× support · 0.8 kN/m² wind/snow load

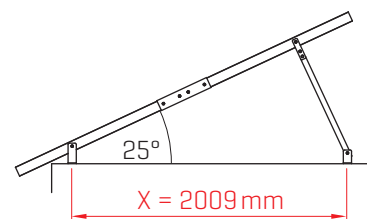
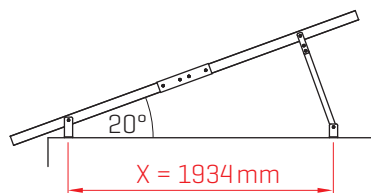
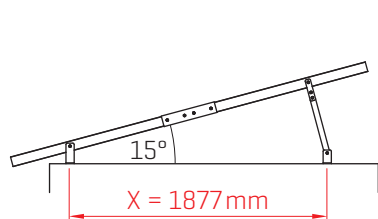
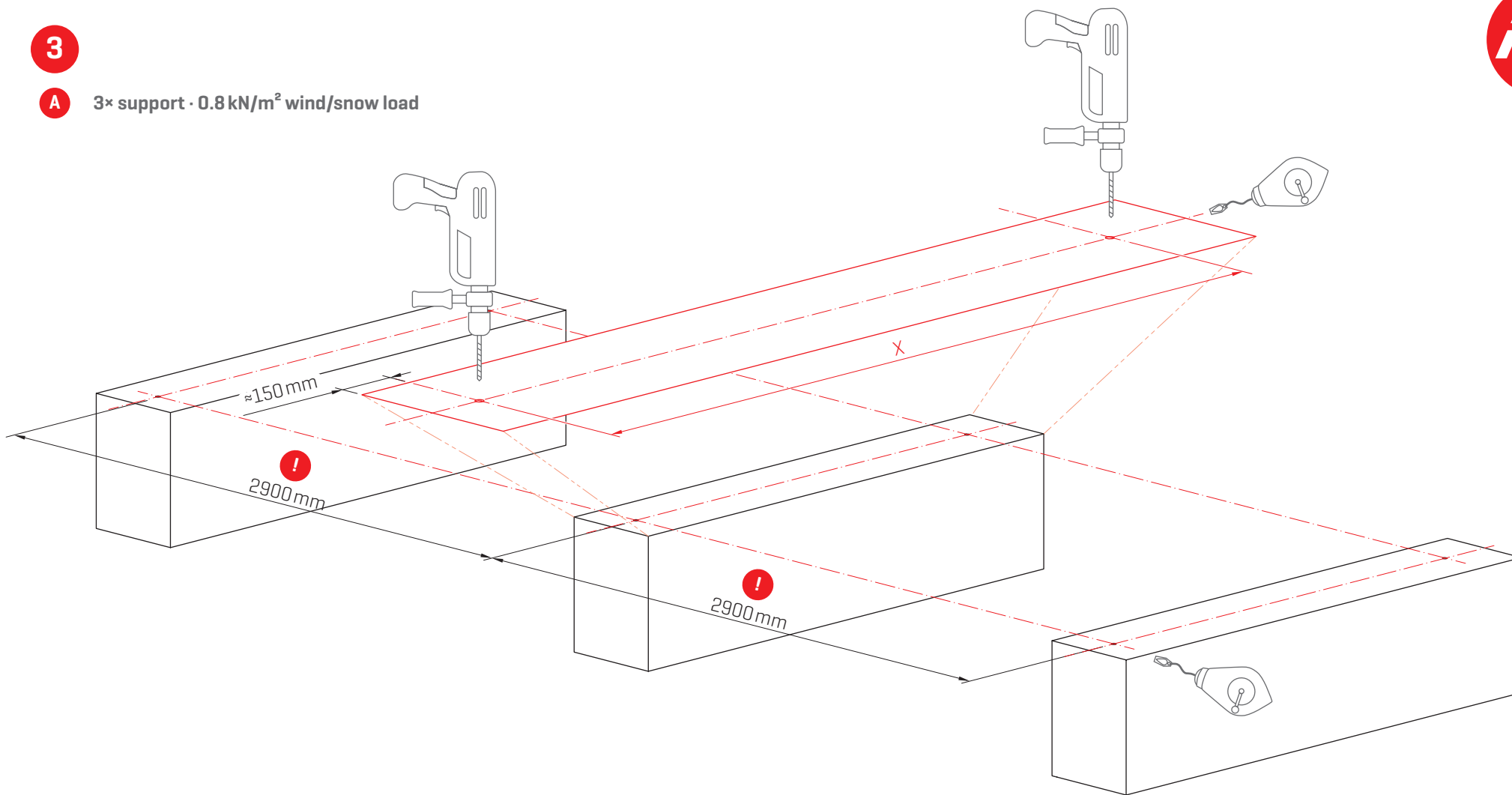

3

B 5× support · 1.3 kN/m² wind/snow load

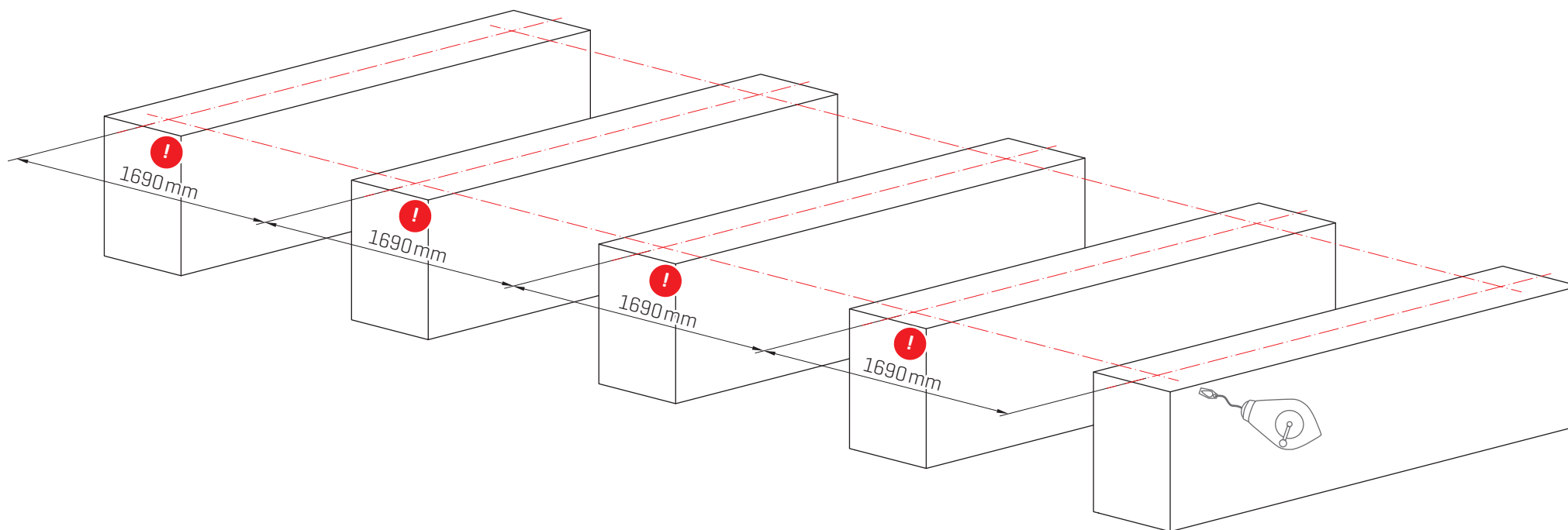

4

! A+B: Torque = 90Nm!

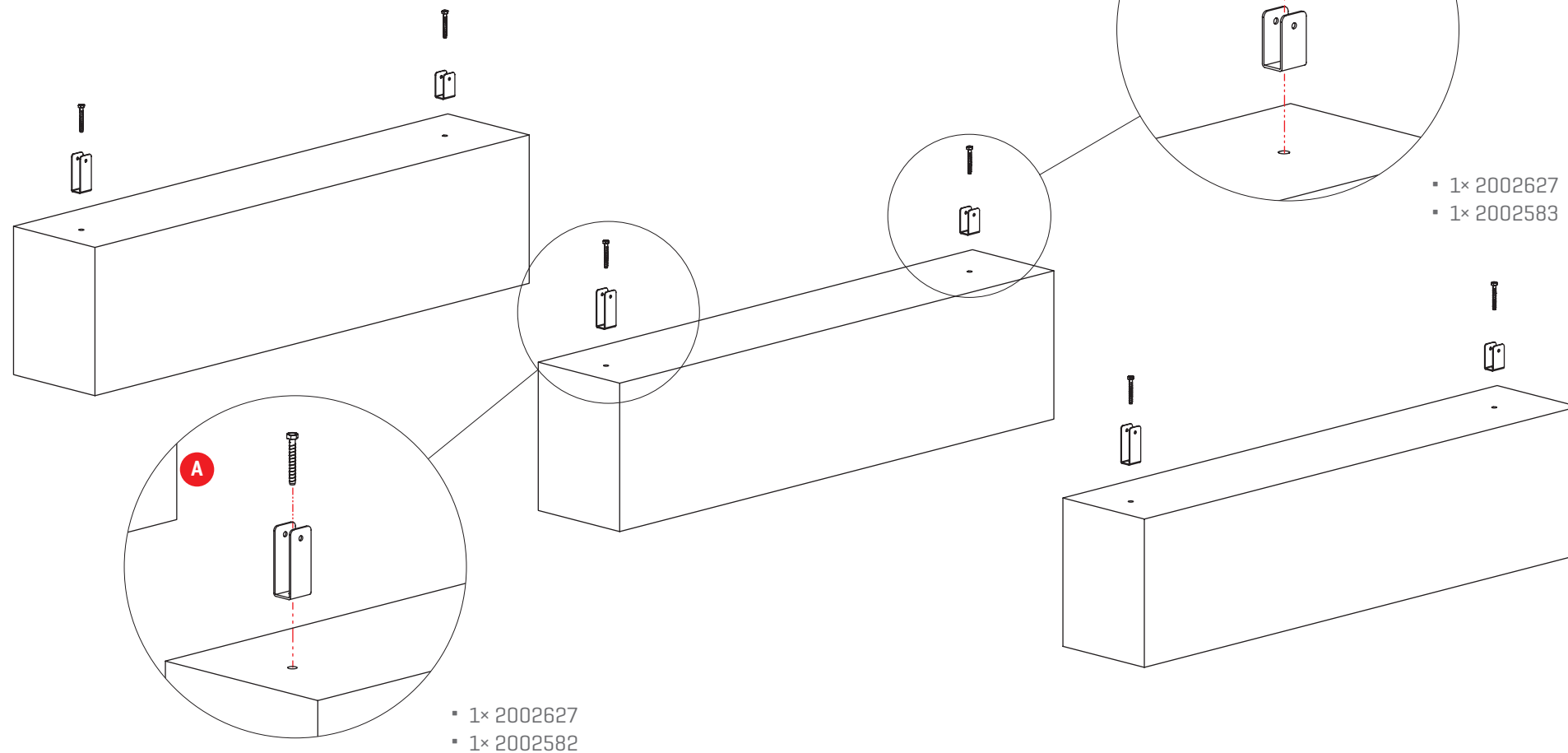

5 3× 5×

! A-C: Torque = 30 Nm!

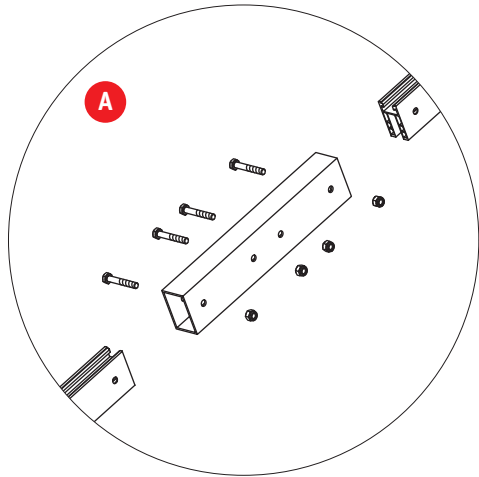
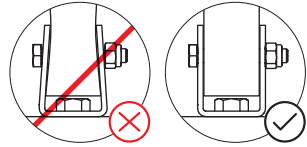

- 2× 2002584
- 1× 2002516
- 4× 2002410
- 4× 1002849

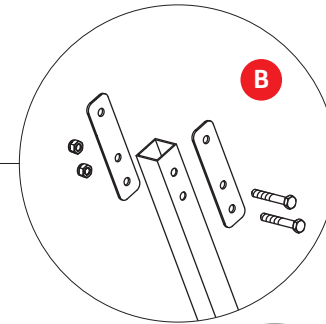
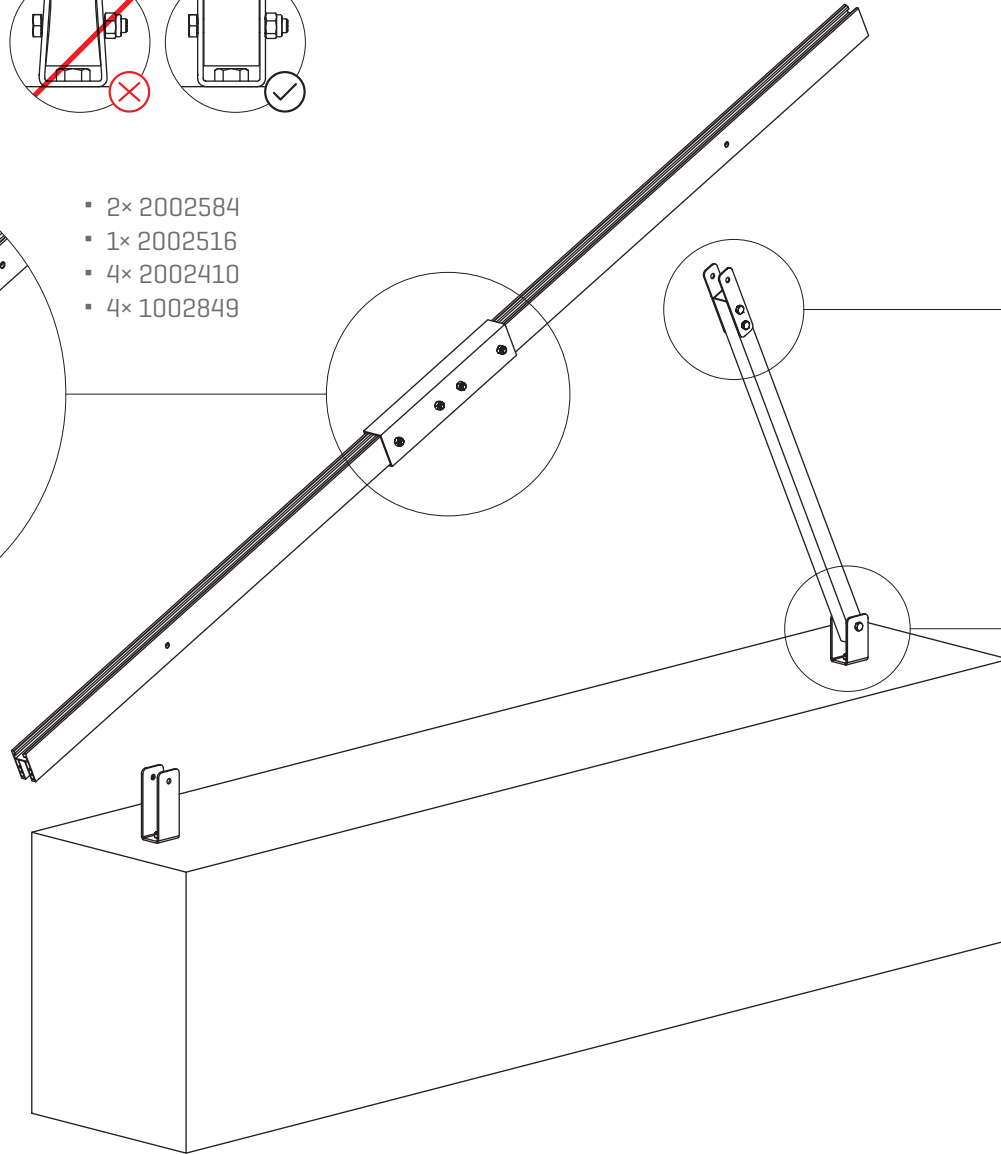

- 1× 2002602
- 2× 2002599
- 2× 2002410
- 2× 1002849

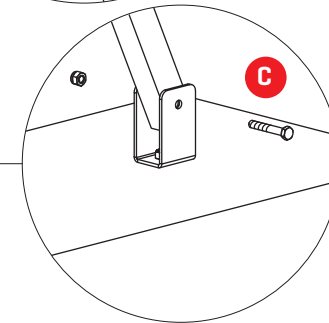

- 1× 2002410
- 1× 1002849

6

3×

5×

! A+B: Torque = 30 Nm!

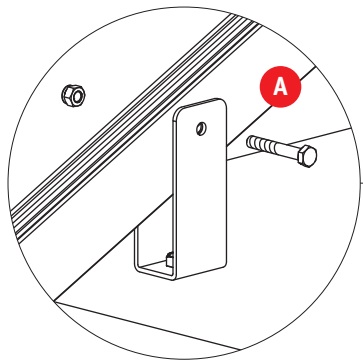
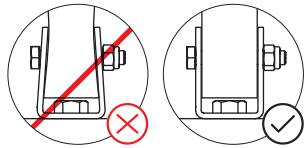

- 1× 2002410
- 1× 1002849

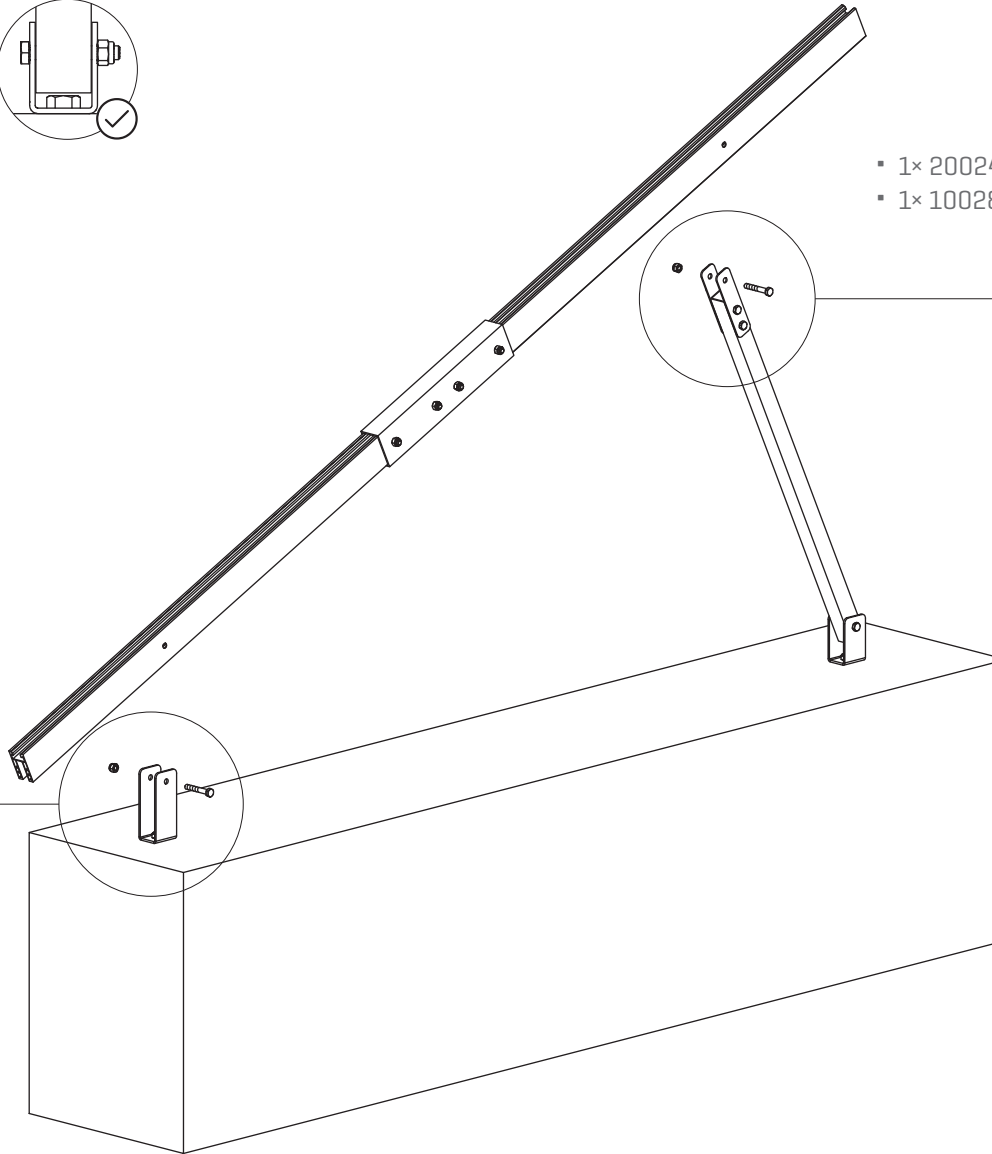

- 1× 2002410
- 1× 1002849

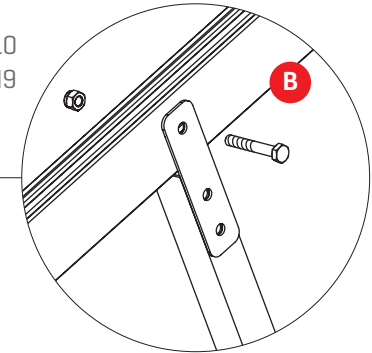

7

4x

- 1x 2002580 / 2002784
- 1x 2002579 / 2002795
- 1x 2001297
- 2x 1001051

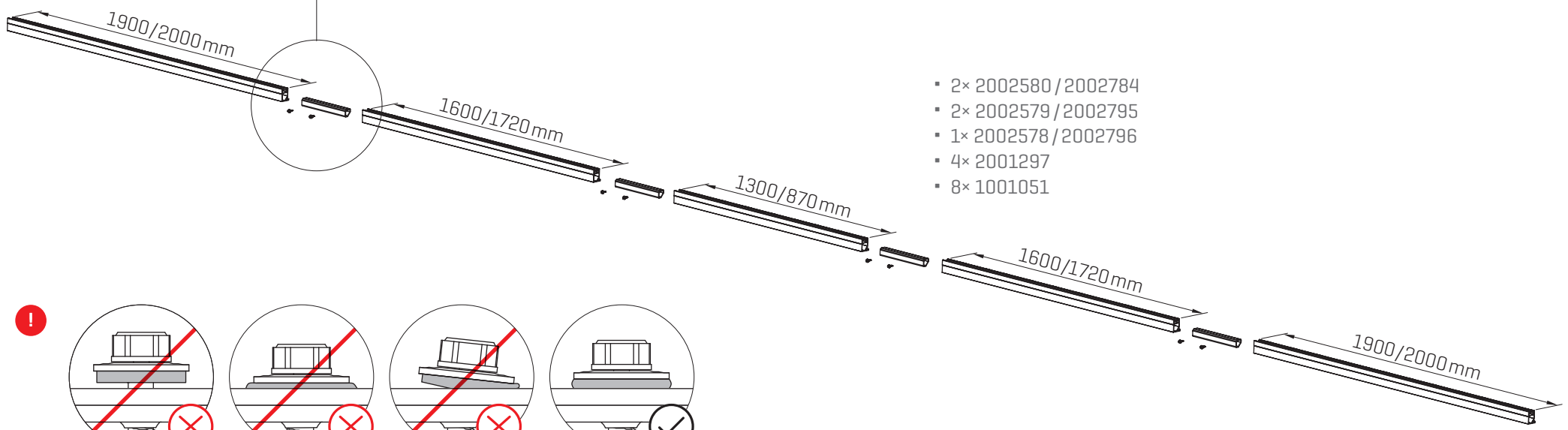
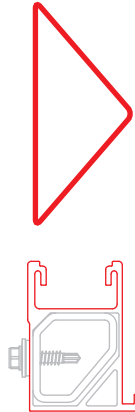
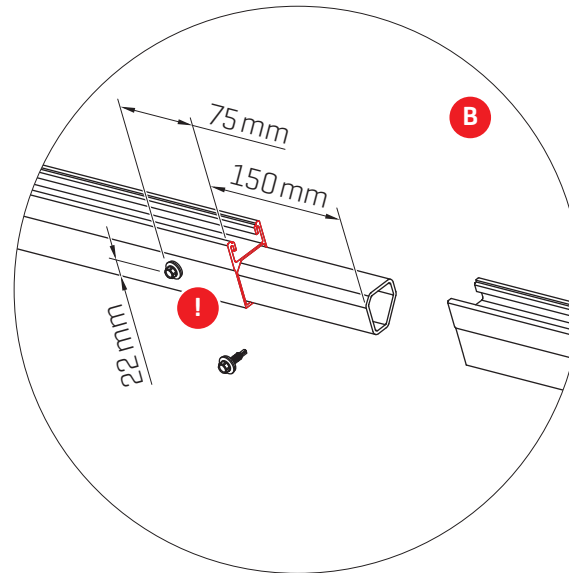
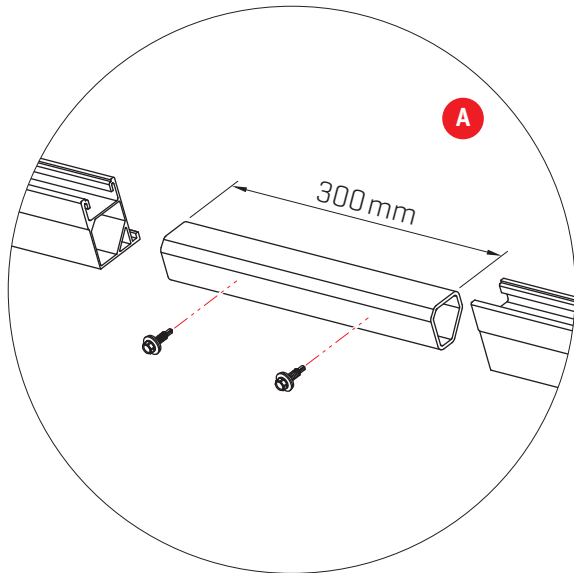

- 2x 2002580 / 2002784
- 2x 2002579 / 2002795
- 1x 2002578 / 2002796
- 4x 2001297
- 8x 1001051

!

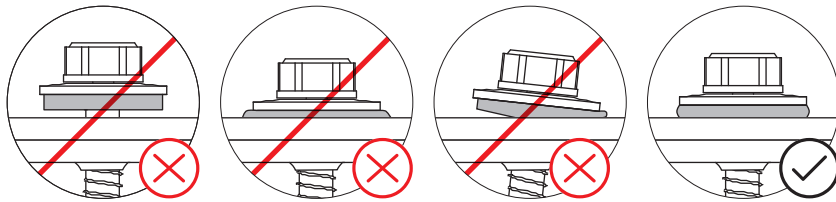

8

! Torque = 14Nm!

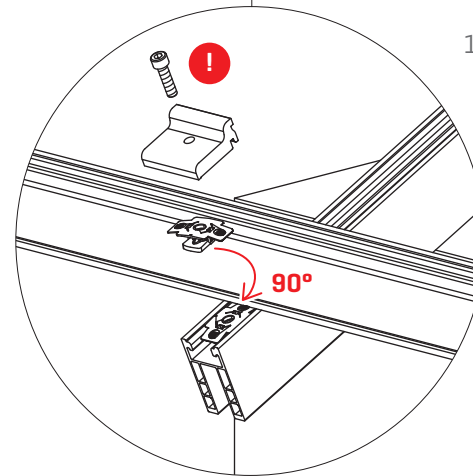
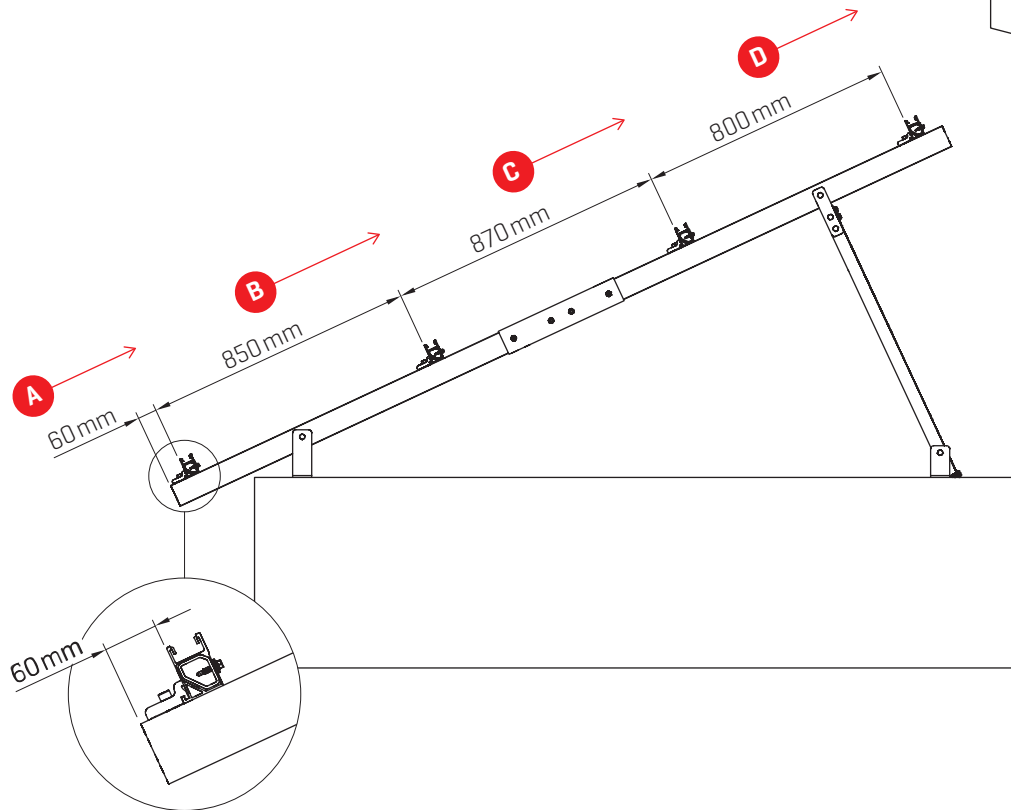
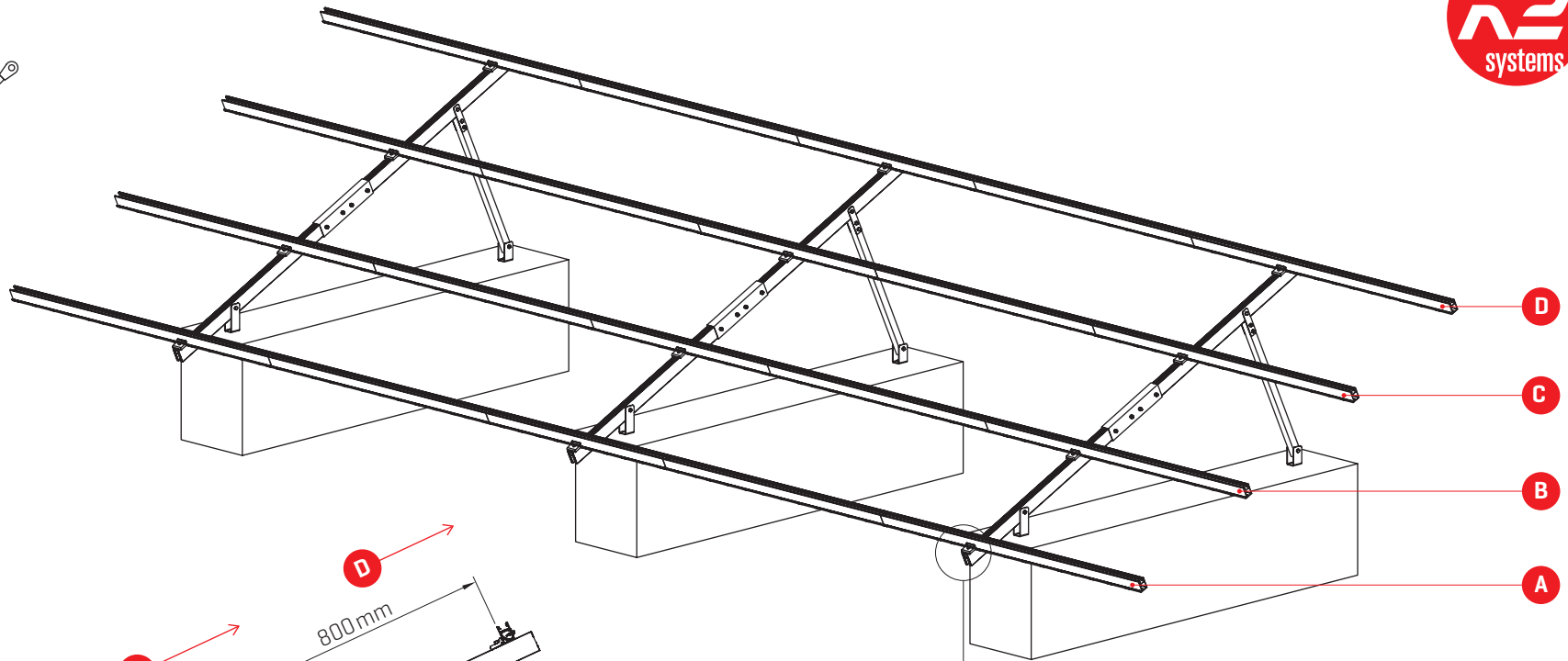

9

! Torque = 16Nm!



- **16 modules** for modules with 1580-1650 × 980-1005 mm
- **14 modules** for modules with 1580-1785 × 980-1150 mm

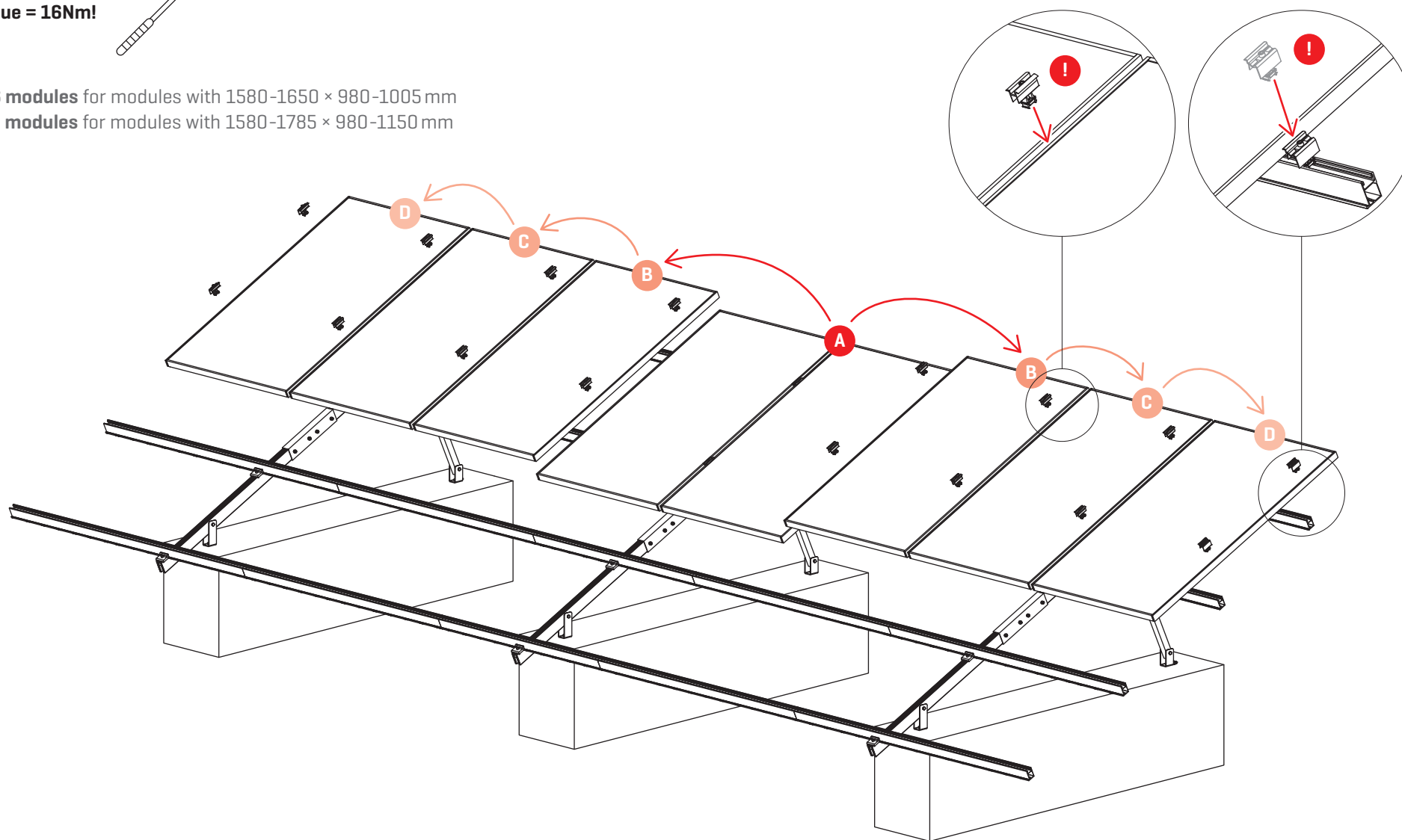

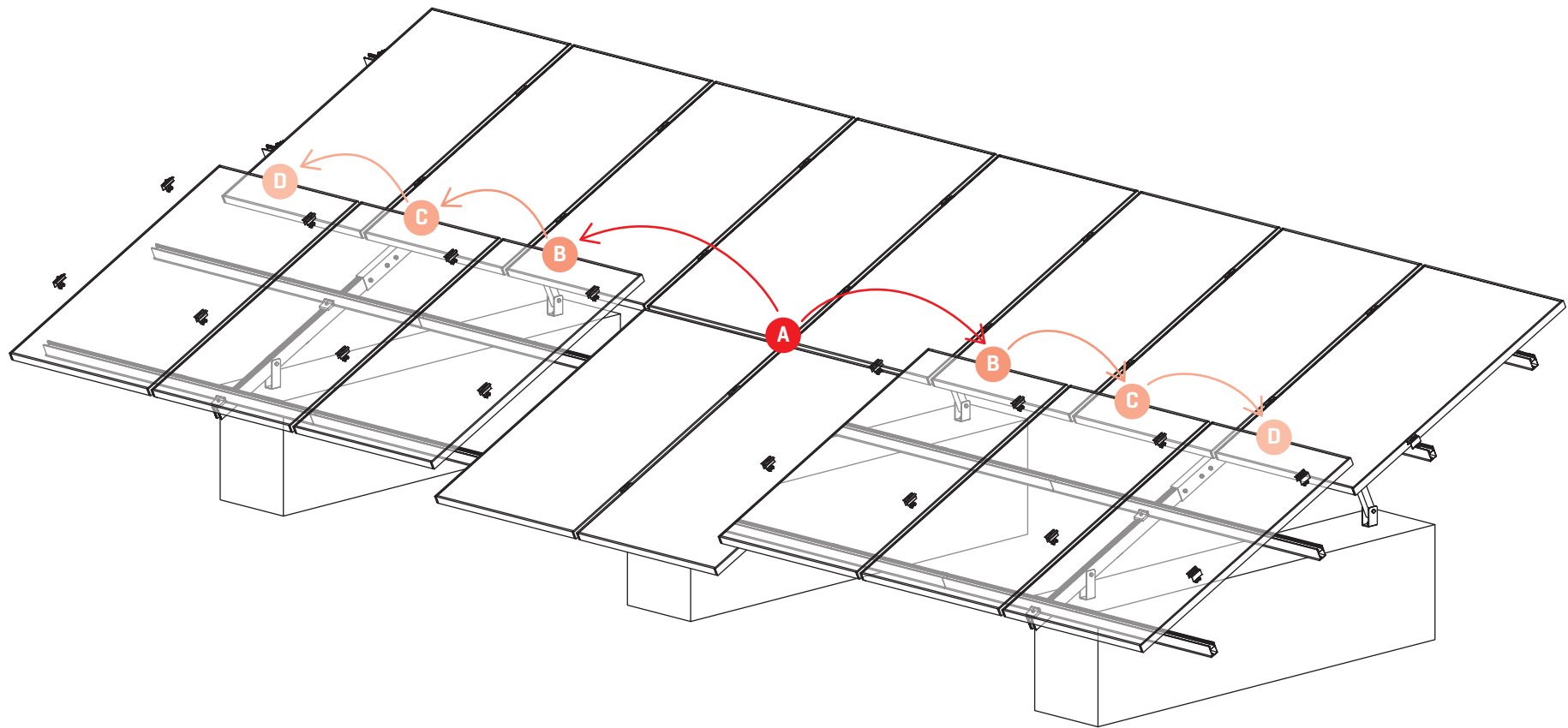

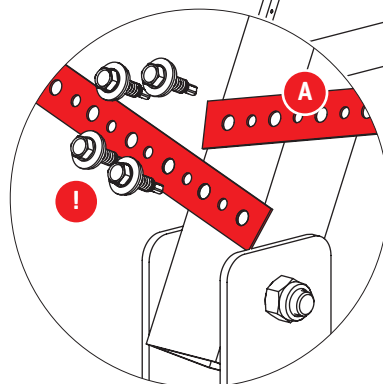
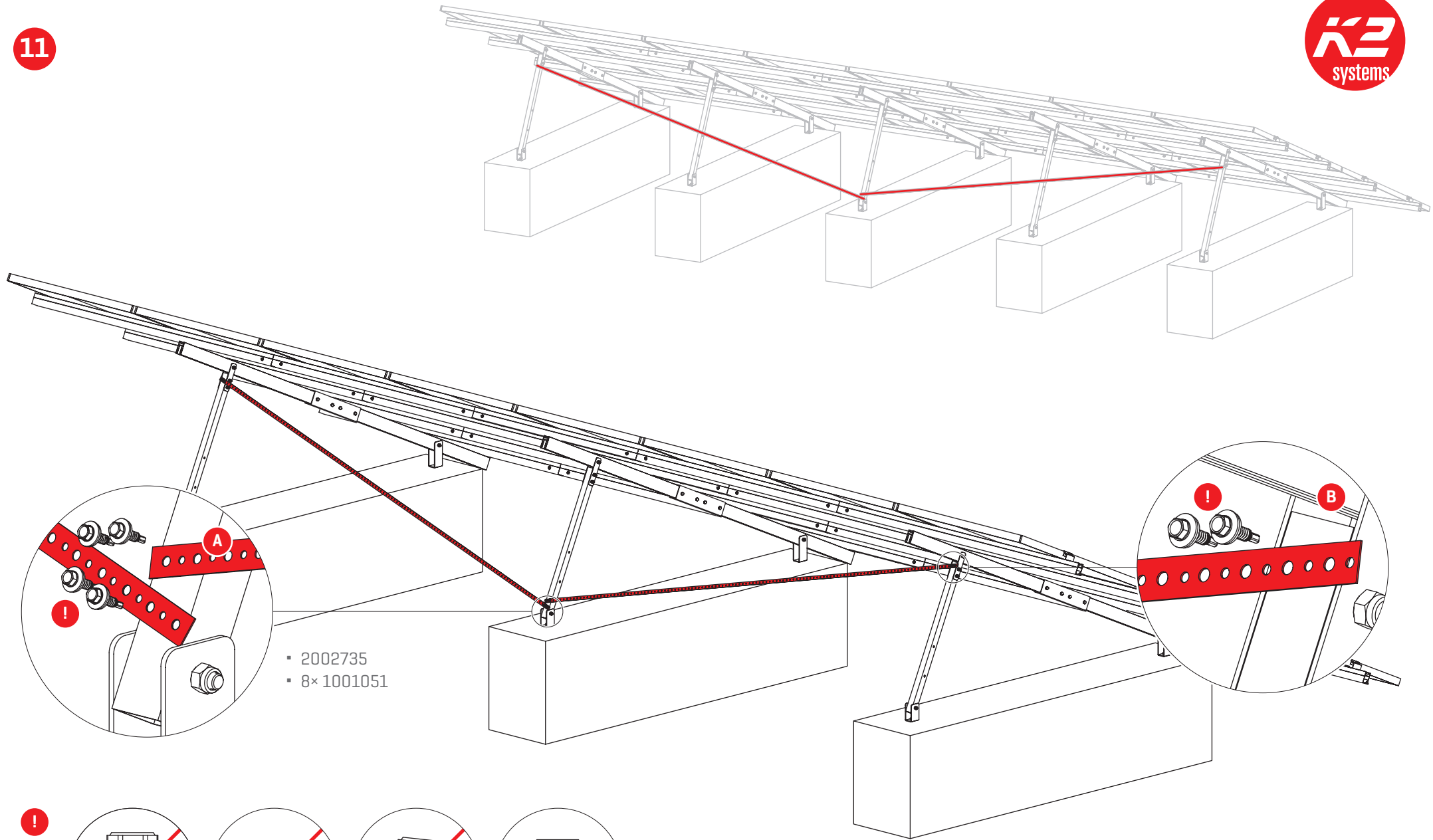

- 2002735
- 8× 1001051

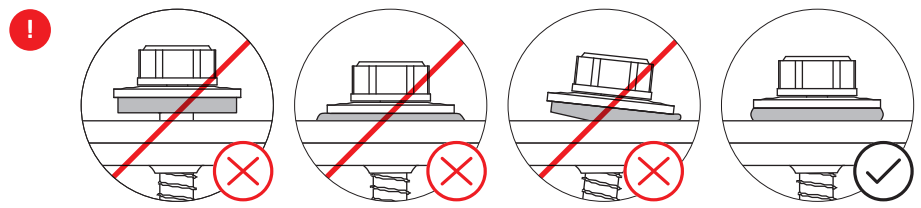
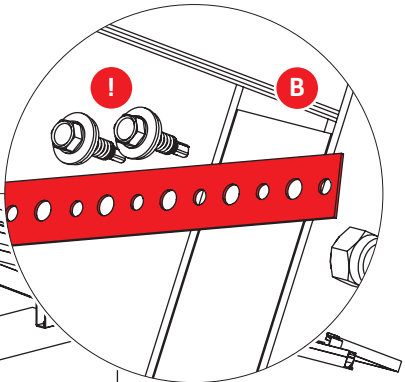

We support PV systems

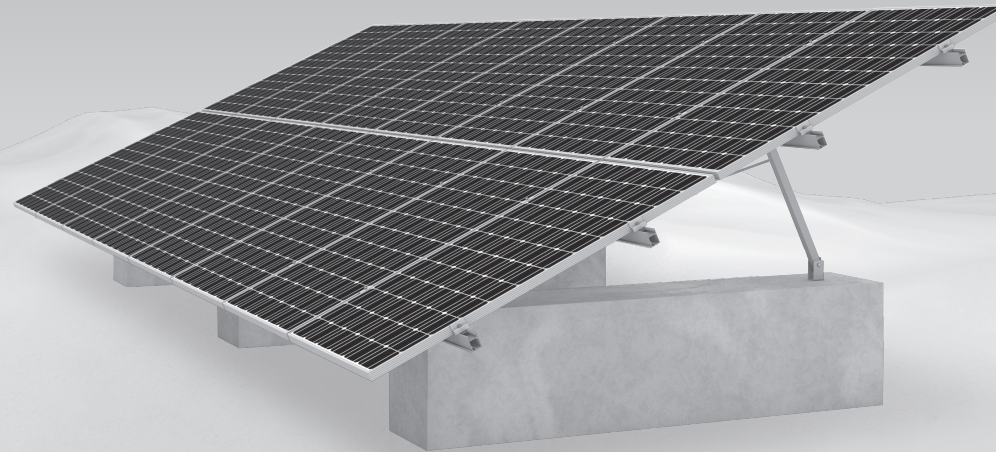

Thank you for choosing a K2 mounting system.

Systems from K2 Systems are quick and easy to install. We hope these instructions have helped.

Please contact us with any questions or suggestions for improvement.

Our contact data:

▶ www.k2-systems.com/en/contact

▶ **Service Hotline: +49 [0]7159 42059-0**

Our General Terms of Business apply. Please refer:

www.k2-systems.com

A-Rack Assembly EN V4 | 0923 · Subject to change · Product illustrations are exemplary and may differ from the original.