



Official Website



APP (iOS)



APP (Android)

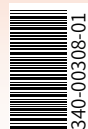

EH SERIES USER MANUAL

HYBRID INVERTER

TABLE OF CONTENTS

01 INTRODUCTION

1.1 OPERATION MODES INTRODUCTION	01
1.2 SAFETY & WARNINGS	02
1.3 PRODUCT OVERVIEW	04

02 INSTALLATION INSTRUCTIONS

2.1 UNACCEPTABLE INSTALLATIONS	05
2.2 PACKING LIST	05
2.3 MOUNTING	06
2.3.1 SELECT MOUNTING LOCATION	06
2.3.2 MOUNTING	07
2.4 ELECTRICAL WIRING CONNECTION	08
2.4.1 PV CONNECTION	08
2.4.2 BATTERY CONNECTION	09
2.4.3 ON-GRID & BACK-UP CONNECTION	10
2.4.4 SMARTMETER & CT CONNECTION	13
2.5 DRED & EARTH FAULT ALARM	14
2.6 EARTH FAULT CONNECTION	14

03 MANUAL OPERATION

3.1 WI-FI CONFIGURATION	17
3.2 PV MASTER APP OPERATION	18
3.3 GEI AUTO-TEST INSTRUCTION	18
3.4 BATTERY FUNCTION ACTIVATION	18

04 OTHERS

4.1 DISCLAIMER	19
4.2 ERROR MESSAGE AND TROUBLESHOOTING	25
4.3 TECHNICAL PARAMETERS AND CERTIFICATES	26
4.4 WARINING QUICK CHECK LIST	28
4.5 CHECKING THE ELECTRICAL CONNECTION	29

01 INTRODUCTION

GoodWe EH series, also called hybrid or bidirectional solar inverters, apply to solar system with participation of PV, battery, loads and grid system for energy management. The energy produced by PV system shall be used to optimize self-consumption, excess power charge battery and the rest power could be exported to the grids. Battery shall discharge to support loads when PV power is insufficient to meet self-consumption. If both PV power and battery power is insufficient, the system will take power from grid to support loads.

In addition, the EH Series includes a Battery-Ready inverter that has no battery function until it is activated. If your inverter is Battery-Ready and not activated now, you can ignore the following battery-related content.

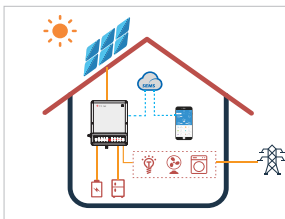

Note: The introduction describes a general behavior of EH system. The operation mode can be adjusted on GoodWe PV Master APP based on the system layout. Below are the general operation modes based on the system layout. Below are the general operation modes for EH system.

1.1 OPERATION MODES INTRODUCTION

EH system normally has the following operation modes based on your configuration and layout conditions.

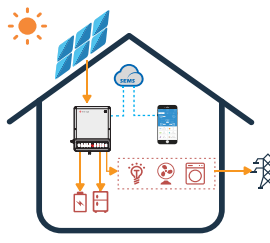

Mode I
The energy produced by the PV system is used to optimize self-consumption. The excess energy is used to charge the batteries, then exported to grid.

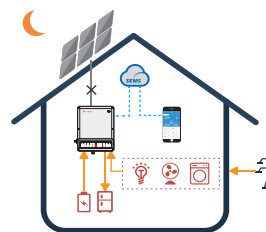

Mode II
When there is no PV, and the battery is sufficient, it can supply the load with the grid together.

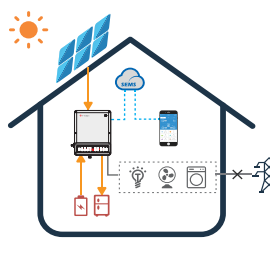

Mode III
When grid fails, the system automatically switches to Back-Up mode, the Back-Up load could be supported by PV and battery.

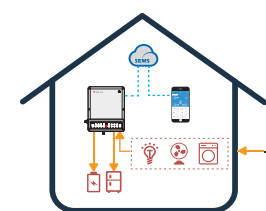













Mode IV
Battery could be charged by grid, and charge time/power could be set flexibly on PV Master APP.

1.2 SAFETY & WARNING

The EH series hybrid inverter of Jiangsu GoodWe Power Supply Technology Co., Ltd. (hereinafter called as GoodWe) strictly comply with related safety rules for product design and testing. Please read and follow all the instructions and cautions on the hybrid inverter or user manual during installation, operation or maintenance, as any improper operation might cause personal or damage.

• SYMBOLS EXPLANATION

-  Caution!
Failing to observe a warning indicated in this manual may result in injury.
-  Danger of high voltage and electric shock!
-  Danger of hot surface!
-  Components of the product can be recycled.
-  This side up! The package must always be transported, handled and stored in such a way that the arrows always point upwards.
-  No more than six (6) identical packages being stacked on each other.
-  Product should not be disposed as household waste.
-  The package/product should be handled carefully and never be tipped over or slung.
-  Refer to the operating instructions.
-  Keep dry! The package/product must be protected from excessive humidity and must be stored under cover.
-  Inverter will be touchable or operable after minimum 5 minutes of being turned off or totally disconnected, in case of any electrical shock or injury.
-  CE Mark

• SAFETY WARNING

Any installation and operation on hybrid inverter must be performed by qualified electricians, in compliance with standards, wiring rules or requirements of local grid authorities or companies (like AS 4777 and AS/NZS 3000 in Australia).

Prohibit to insert or pull the AC and DC terminals when the inverter is running.

Before any wiring connection or electrical operation on inverter, all battery and AC power must be disconnected from inverter for at least 5 minutes to make sure inverter is totally isolated to avoid electric shock.

The temperature of inverter surface might exceed 60°C during working, so please make sure it is cooled down before touching it, and make sure the inverter is untouchable for children

Do not open inverter cover or change any components without GoodWe's authorization, otherwise the warranty commitment for the inverter will be invalid.

Usage and operation of the inverter must follow instructions in this user manual, otherwise the protection design might be useless and warranty for the inverter will be invalid.

Appropriate methods must be adopted to protect inverter from static damage. Any damage caused by static is not warranted by GoodWe.

PV negative (PV-) and battery negative (BAT-) on inverter side is not grounded as default design. Connecting PV- or BAT- to EARTH are strictly forbidden.

PV modules used on the inverter must have an IEC61730 class A rating, and the total open-circuit voltage of PV string/array is lower than the maximum rated DC input voltage of the inverter. Any damage caused by PV over-voltage is beyond warranty.

The inverter, with built-in RCMU, will exclude possibility of DC residual current to 6mA, thus in the system an external RCD (type A) can be used(≥30mA).

In Australia, the inverter internal switching does not maintain neutral integrity, which must be addressed by external connection arrangements like in the system connection diagram for Australia on page 16.

In Australia, output of Back-Up side in switchbox should be labeled 'Main switch UPS supply', the output of normal load side in switch box should be labeled 'main switch inverter supply'.

I.3 PRODUCT OVERVIEW

HYBRID LED INDICATORS		
INDICATOR	STATUS	EXPLANATION
SYSTEM	ON = SYSTEM IS READY BLINK = SYSTEM IS STARTING UP OFF = SYSTEM IS NOT OPERATING	
BACK-UP	ON = BACK-UP IS READY / POWER AVAILABLE OFF = BACK-UP IS OFF / NO POWER AVAILABLE ON = BATTERY IS CHARGING BLINK 1 = BATTERY IS DISCHARGING BLINK 2 = BATTERY IS LOW / SOC IS LOW OFF = BATTERY IS DISCONNECTED / NOT ACTIVE	
BATTERY	ON = GRID IS ACTIVE AND CONNECTED BLINK = GRID IS ACTIVE BUT NOT CONNECTED OFF = GRID IS NOT ACTIVE ON = CONSUMING ENERGY FROM GRID / BUYING BLINK 1 = SUPPLYING ENERGY TO GRID / ZEROS BLINK 2 = SUPPLYING ENERGY TO GRID / SELLING OFF = GRID NOT CONNECTED OR SYSTEM NOT OPERATING	
GRID	ON = HANS AND METER COMMUNICATION OK BLINK 1 = METER COMMUNICATION OK, BMS COMMUNICATION FAIL BLINK 2 = BMS COMMUNICATION OK, METER COMMUNICATION FAIL OFF = BMS AND METER COMMUNICATION FAIL	
COM	ON = WIFI CONNECTED ACTIVE BLINK 1 = WIFI SYSTEM RESETING BLINK 2 = WIFI NOT CONNECT TO ROUTER BLINK 4 = WIFI SERVER PROBLEM OFF = WIFI NOT ACTIVE	
WIFI	ON = FAULT HAS OCCURRED BLINK = OVERLOAD OR BACKUP OUTPUT / REDUCE LOAD OFF = NO FAULT	
FAULT		

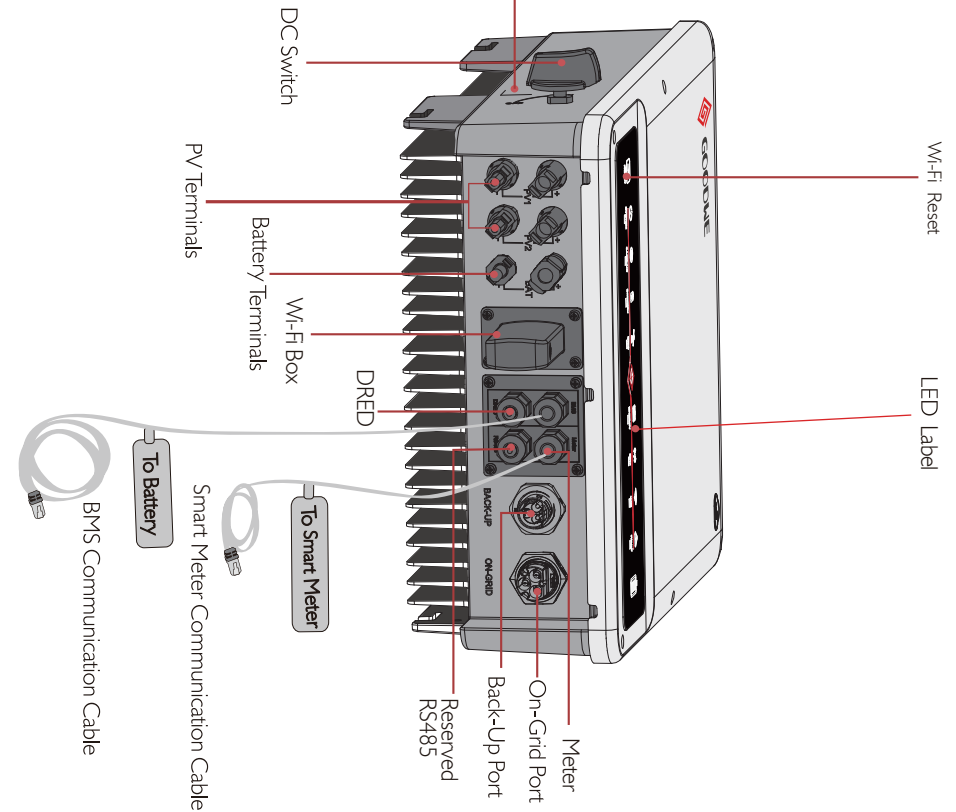

02 **INSTALLATION INSTRUCTIONS**

2.1 UNACCEPTABLE INSTALLATIONS

<p>Back-Up Load Back-Up</p> <p>BACK-UP CANNOT CONNECT IN PARALLEL.</p>	<p>PV PV</p> <p>SINGLE PV STRING CANNOT CONNECT TO TWO OR MORE INVERTERS.</p>	
<p>Smart Meter</p> <p>ONE METER CANNOT CONNECT TO MULTI INVERTERS, AND DIFFERENT CT CANNOT CONNECT TO A SAME FIER CABLE.</p>	<p>BATTERY Battery Battery</p> <p>ONE BATTERY BANK CANNOT BE CONNECTED TO MULTI INVERTERS.</p>	
<p>Generator</p> <p>Back-Up On-Grid</p> <p>ON-GRID OR BACK-UP SIDE CANNOT CONNECT TO ANY AC GENERATOR.</p>	<p>Incompatible battery</p> <p>BATTERY</p> <p>INVERTER BATTERY CANNOT CONNECT TO INCOMPATIBLE BATTERIES</p>	<p>Back-Up On-Grid</p> <p>BACK-UP SIDE CANNOT CONNECT TO GRID</p>

2.2 PACKING LIST

On receiving the hybrid inverter, please check to make sure all the components as below are not missing or broken. Of course, there are no Smart Meter and Smart Meter User Manual if you buy a Battery-Ready inverter without the Smart Meter.

Inverter x1	Wall-mounted Bracket x1	Smart Meter & CT x1	Positive PV Plug x2	Negative PV Plug x2	Positive BAT Plug x1	Negative BAT Plug x1
Back Up AC Plug x1	On Grid AC Plug x1	PE terminal x1	Expansion bolts x4	User manual x1	Quick Installation Guide x1	

2.3 MOUNTING

2.3.1 SELECT MOUNTING LOCATION

For inverter's protection and convenient maintenance, mounting location for inverter should be selected carefully based on the following rules:

Any part of this system shouldn't block the switch and breaker to disconnected inverter from DC and AC power.

Rule 1. Inverter should be installed on a solid surface, where is suitable for inverter's dimensions and weight.

Rule 2. Inverter installation should stand vertically or lie on a slop by max 15° (Pic 1)

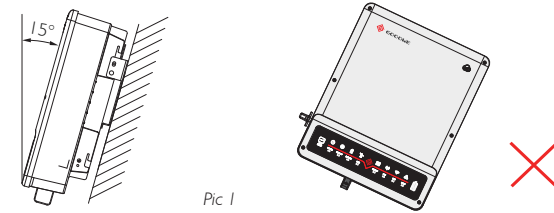

Rule 3. Ambient temperature should be lower than 45°C

Rule 4. The installation of inverter should be protected under shelter from direct sunlight or bad weather like snow, rain, lightning etc. (Pic 2)

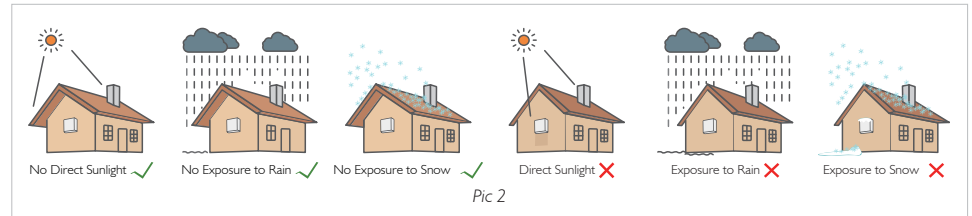

Rule 5. Inverter should be installed at eye level for convenient maintenance.

Rule 6. Product label on inverter should be clearly visible after installation.

Rule 7. Leave enough space around inverter following the values on pic 3.

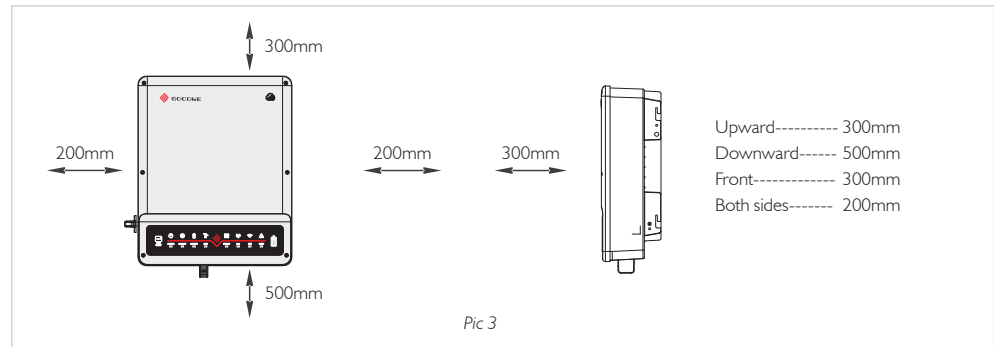

Inverter cannot be installed near flammable, explosive or strong electro-magnetic equipment.^[1]

2.3.2 MOUNTING

! Remember that this inverter is heavy! Please be careful when lifting out from the package.^[3]

The inverter is suitable for mounting on concrete or other non-combustible surface only

Step 1

- Please use the mounting bracket as a template to drill 4 holes on right positions (10mm in diameter, and 80mm in depth) (Pic 4)
- Use expansion bolts in accessory box and fix the mounting bracket onto the wall tightly

Note: Bearing capacity of the wall must be higher than 17kg, otherwise may not be able to keep inverter from dropping.

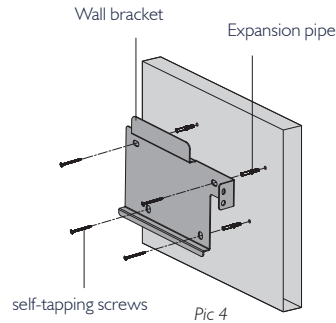

07

Step 2

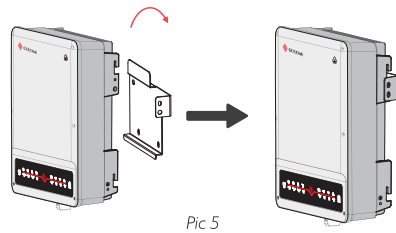

Carry the inverter by holding the heating sink on two sides and Place the inverter on the mounting bracket. (Pic 5)

Note: Make sure the heat sink on inverter is right joint with mounting bracket.

Step 3

Ground cable shall be connected to ground plate on grid side (Pic 6)

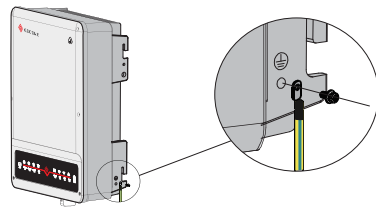

Pic 6

Step 4

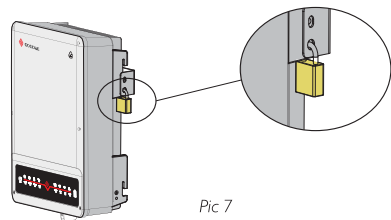

Pic 7

A lock could be used for anti-theft if it is necessary for individual requirement. (Pic 7)

2.4 ELECTRICAL WIRING CONNECTION

2.4.1 PV WIRING CONNECTION

Before connecting PV panels/strings to inverter, please make sure requirements are followed as below :

- The total short-circuit current of PV string must not exceed inverter's max DC current .
- The minimum isolation resistance to ground of the PV string must exceed 19.33kΩ in case of any shock hazard .
- PV strings could not connect to earth/grounding conductor .
- Use the right PV plugs in the accessory box .
(BAT plugs are similar with PV plugs, please confirm before use it.)

NOTE: There will be MC4 or Amphenol plugs in accessory box, the detailed connection as below:

Step 1

Prepare PV cables and PV plugs (Pic 8)

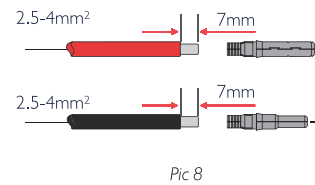

Pic 8

NOTE:

- Please use PV plugs and connectors in GoodWe accessory box
- PV cable should be standard, 2.5-4mm² PV cable

Step 2

Connect PV cable to PV connectors (Pic 9)

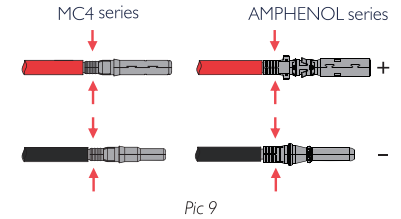

Pic 9

NOTE:

- PV cable must be tightly crimped into the connectors
- For Amphenol connector, the limit buckle cannot be pressed
- There will be a click sound if connectors are inset correctly into PV plugs

Step 3

Screw the cap on and plug onto inverter side (Pic 10)

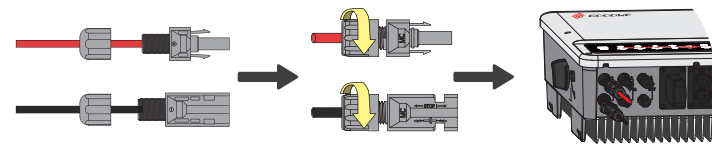

Pic 10

NOTE:

- There will be a click sound if connectors are inset correctly into PV plugs



The polarity of PV strings or on the inverter cannot be connected by reversely, otherwise inverter could be damaged.^[3]

08

2.4.2 BATTERY WIRING CONNECTION

If your inverter is Battery-Ready, do not connect the battery to the inverter before activating the battery function, otherwise it will stop working! Besides, do not remove the battery plug and save the battery terminals, if lost, contact GOODWE for sale.

- Please be careful against any electric shock or chemical hazard.
- Make sure there is an external DC breaker ($\geq 40A$) connected for battery without build-in DC breaker.

! Make sure battery breaker is off and battery nominal voltage meet EH specification before connecting battery to inverter and make sure inverter is totally isolated from PV and AC power.^[4]

Please following Cments and steps bellow strictly. Use improper wire may cause bad contact and high impedance, which is dangerous to the system.

- Use the right BAT plugs in the accessory box.
- Use the tin-plated cables with a conductor cross section of 4 to 6 mm² (AWG 10) because the maximum battery current is 25A. Battery cable requirements are as (Pic 11).

Grade	Description	Value
A	Outside Diameter	5.5-8.0 mm
B	Conduct Core Section	4-6 mm ²
C	Conduct Wire Length	15 mm

- Battery wiring connection process is as below

Step 1

Open the spring using a screwdriver (Pic12)

Step 2

Carefully insert the stripped wire with twisted litz wires all the way in (A). The litz wire ends have to be visible in the spring. Close the spring. Make sure that the spring is snapped in (B).

Step 3

Push the insert into the sleeve (C). Tighten the cable gland to 2 Nm (D). Use a suitable and calibrated torque wrench, size 15. Use an open-jaw wrench, size 16, to hold the connector in place.

Step 4

Fit the two connectors together until the connection audibly locks into place. Check to make sure the connection is securely locked.

* For the compatible lithium batteries (Pylon/BYD) connection, please refer to battery connection part in EH QUICK INSTALLATION INSTRUCTIONS

2.4.3 ON-GRID & BACK-UP CONNECTION

An external AC breaker is needed for On-Grid connection to be isolate from grid when necessary. Below are the requirements of On-Grid AC breaker.

Inverter model	AC breaker specification
GW3600-EH	50A/230V AC breaker
GW5000-EH	63A/230V AC breaker
GW6000-EH	63A/230V AC breaker

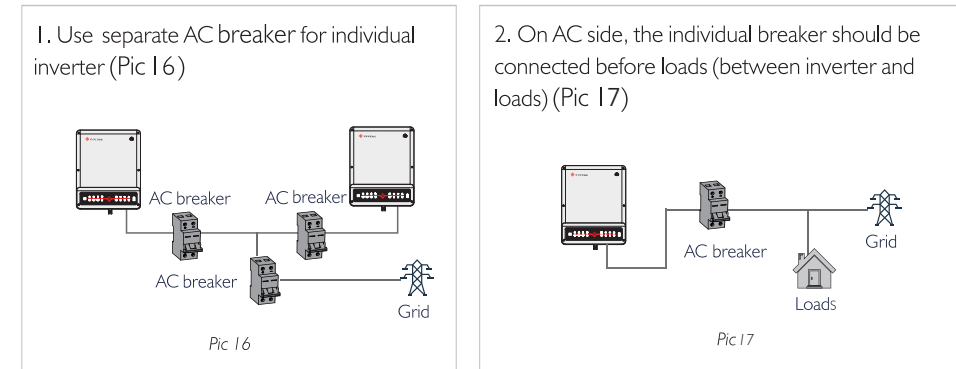

- Requirement of AC cable connected to On-Grid and Back-Up side

! Make sure inverter is totally isolated from any DC or AC power before connecting AC cable.^[5]

- Note:**
1. The choice of AC cable needs to meet both the outside diameter and conduct core section requirements. Please refer to the table for selecting the AC cable.
 2. Neutral cable shall be blue, line cable is black or brown (preferred) and protective earth cable yellow-green.
 3. For AC cables, PE cable shall be longer than N&L cables, so that if in any case AC cable slips or taken out, the protecting earth conductor will be the last to take the strain.

- On-Grid wiring connection process is as below

Step 1

Prepare the AC cable according to the table.

Grade	Description	Value
A	Outside Diameter	13-22mm
B	Separated Wire Length	10-15mm
C	Conduct Wire Length	12-14mm
D	Conduct Core Section	8-10 mm ²

Note: If you don't use the back-up function or use on-grid power to charge the battery, the wiring conduct core section can use 4-6mm².

Step 2

1. Prepare the terminals and AC cables
2. Put AC cable through terminal cover and screw the three cables tightly on the connectors (Pic 18)

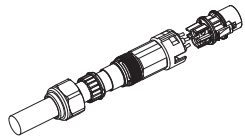

Pic 18

NOTE:

1. Please use the terminals in GoodWe components box;
2. Make sure cable jacket is not locked with conductor

- Back-Up wiring connection process is as below

Step 1

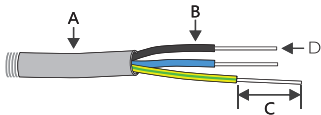

Pic 21

Grade	Description	Value
A	Outside Diameter	10-14mm
B	Separated Wire Length	7-10mm
C	Conduct Wire Length	7-9mm
D	Conduct Core Section	4-6mm ²

Note: The absence of AC breaker on Back-Up side will lead to inverter damage if only electrical short-circuit happened on Back-Up side. And Back-Up function cannot turn off under On-Grid condition.

An external AC breaker ($\geq 32A$) is needed for Back-Up connection to be isolate when necessary.

Step 2

1. Prepare the terminals and AC cables
2. Put AC cable through terminal cover and screw the three cables tightly on the connectors (Pic 22)

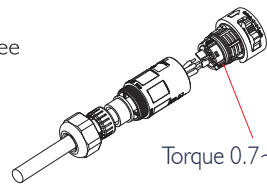

Pic 22

NOTE:

1. Please use the terminals in GoodWe components box;
2. Make sure cable jacket is not locked with conductor

Step 3

Lock terminal cover and screw up the terminal cap

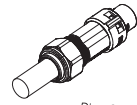

Pic 19

Make sure terminal cover is locked up here.

Note: Make sure the terminal cover is rightly locked onto the terminal (Pic 19)

Step 4

Connect the assembled AC terminals onto inverter

Note: Make sure it is connected to 'On-Grid' side (other side connected to public grid) (Pic 20)

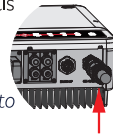

Pic 20

Step 3

Lock terminal cover and screw up the terminal cap

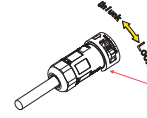

Pic 23

Make sure terminal cover is locked up here.

Note: Make sure the terminal cover is rightly locked onto the terminal (Pic 23)

Step 4

Connect the assembled AC terminals onto inverter



Press the button and hold it to unlock when unplugging AC terminals.



Pic 24

Note: Make sure it is connected to 'Back-Up' side (other side connected to public grid) (Pic 24)

Special Adjustable Setting

The inverter has filed adjustable setting like tripping point, tripping time, reconnect time, active and invalid of QU/PU curves etc. by special firmware. Please contact GoodWe after sales for the special firmware and adjust methods.

Connection For SPLIT Grid System

In SPLIT grid system, there is a solution allowing inverter to work under On-Grid condition (Pic 25). But the export power and load power might be detected inaccurately as the nominal output power of inverter is 230V and there could be loads of 110V or 220V.

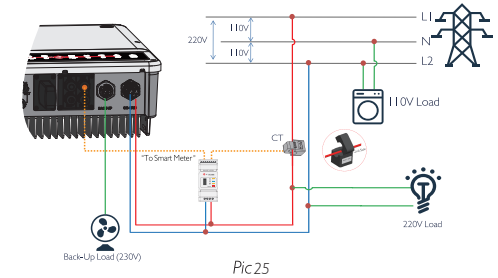

Pic 25

Declaration For Back-Up Function

The below statement lays out GoodWe general policies governing the energy storage inverters of the series ES, EM, SBP, ET, EH and BH.

1. For Hybrid inverters (Series ES, EM, EH and ET), the standard PV installation typically consists of the connection of the inverter with both panels and batteries. In case of systems not connected to the batteries, the Back-Up function is strongly not advised to use. GoodWe shall not cover the standard warranty and be liable for any consequences arising from users not following this instruction.

2. Under normal circumstances, the Back-Up switching time is less than 10 ms (the minimal condition to be considered as the UPS level). However, some external factors may cause the system to fail on Back-Up mode. As such, we recommend the users to be aware of conditions and follow the instructions as below:

- 1) Do not connect loads if they are dependent on a stable energy supply for a reliable operation
- 2) Do not connect the loads which may in total exceed the maximum Back-Up capacity
- 3) Try to avoid those loads which may create very high start-up current surges such as Inverter Air-conditioner, high-power pump etc.
- 4) Due to the condition of battery itself, battery current might be limited by some factors including but not limited to the temperature, weather etc.

Declaration For Back-Up Loads

EH series hybrid inverters are able to supply over load output at its' Back-Up. For details please refer to the technical parameters of EH series inverter (4.3 section). And the inverter has self-protection derating at high ambient temperature.

Accepted loads as below:

- Inductive Load: 1.5P non-frequency conversion air-conditioner can be connect to back-up side. Two or more non-frequency conversion air-conditioner connect to back-up side may cause UPS mode unstable.
- Capacitive Load: Total power $\leq 0.6 \times$ nominal power of model. (Any load with high inrush current at start-up is not accepted.)
- For complicated application, please contact GoodWe's after service.

Note:

For a convenient maintenance, an DP3T support could be installed on Back-Up and On-Grid side. Then it is adjustable to support load by Back-Up or by grid or just leave it there (Pic 26).

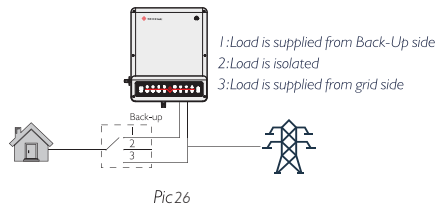

Declaration For Back-Up Overload Protection

Inverter will restart itself as overload protection happens. The preparation time for restarting will be longer and longer (max one hour) if overload protection repeats. Take following steps to restart inverter immediately.

- Decrease Back-Up load power within max limitation.
- On PV Master → Advanced Setting → Click “Reset Back-Up Overload History”

2.4.4 SMART METER & CT CONNECTION

! Make sure AC cable is totally isolated from AC power before connecting Smart Meter & CT.^[6]

If you buy a Battery-Ready inverter without the Smart Meter, it is not necessary to view this section. The Smart Meter with CT in GoodWe product box is compulsory for EH system installation, used to detect grid voltage and current direction and magnitude, further to instruct the operation condition of EH inverter via RS485 communication.

NOTE:

1. The Smart Meter and CT is well configured, please do not change any setting on Smart Meter;
2. One Smart Meter can only be used for one EH inverter.
3. CT must be connected on the same direction as the CT indicated.

Smart Meter & CT Connection Diagram (Pic 27)

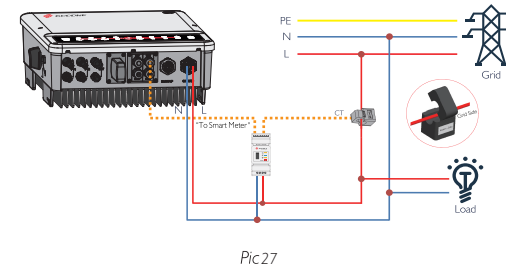

NOTE:

1. Please use the Smart Meter with CT in GoodWe product box.
2. CT cable is 3m as default, could be extended to max 5m.
3. Smart Meter communication cable (RJ45) is attached on the inverter (“To Smart Meter” cable), could be extended to max 100m, and must use standard RJ45 cable and plug, as below:

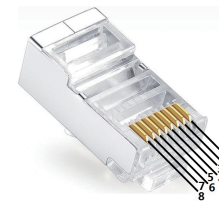

Position	Color	BMS Function	Smart Meter Function	RS485
1	Orange&white	485_A2	NC	485_A
2	Orange	NC	NC	485_B
3	Green&white	485_B2	485_B1	485_A
4	Blue	CAN_H	NC	NC
5	Blue&white	CAN_L	NC	NC
6	Green	NC	485_A1	485_B
7	Brown&white	NC	485_B1	NC
8	Brown	NC	485_A1	NC

Smart Meter LED Indications

	OFF	ON	Blinking
POWER	Not working	Working	/
ENERGY	/	Importing	Exporting
COM	Blink one time when it transfer data to inverter		

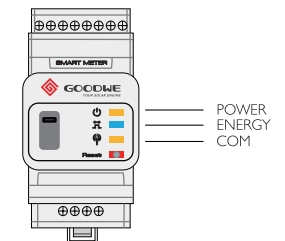

2.5 DRED & REMOTE SHUTDOWN CONNECTION

DRED is used for Australia and New Zealand installation (also used as remote shutdown function in European countries), in compliance with Australia and New Zealand safety requirements(or European countries). And DRED device is not provided by GoodWe.

Detailed connection of DRED device is shown below:

Step 1

Screw this plate off from inverter (Pic 28).

Note: DRED device should be connected through "DRED port" as the figure shows.

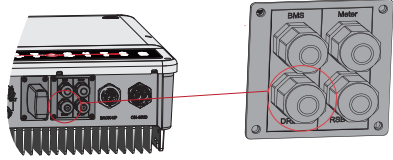

Pic 28

Step 2

1. Plug out the 6-pin terminal and dismantle the resistor on it (Pic 29).
2. Plug the resistor out, leave the 6-pin terminal for next step.

Note: the 6-Pin terminal in the inverter has the same function of DRED device. Please leave it on the inverter if no external device connected.

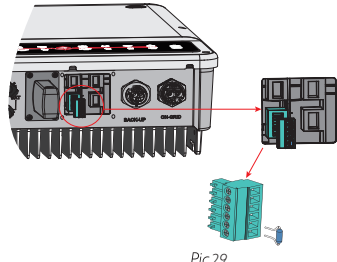

Pic 29

Step 3-1 For DRED

1. Put DRED cable through the plate as shown in Pic 30.
2. Connect DRED cable on the 6-pin terminal.

The function of each connection position as below:

NO	1	2	3	4	5	6
Function	DRM1/5	DRM2/6	DRM3/7	DRM4/8	REFGEN	COM/DRMO

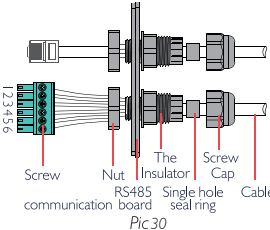

Pic 30

Step 3-2 For Remote Shutdown

1. Put the cable through the plate as shown in Pic 31.
2. Wiring from the No. 5 and 6 holes respectively.

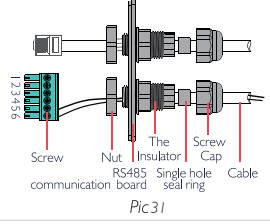

Pic 31

Step 4

Connect DRED terminal to the right position onto the inverter (Pic 32).

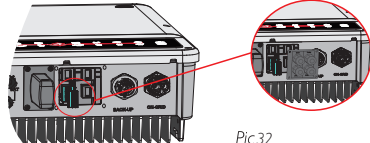

Pic 32

2.6 EARTH FAULT ALARM CONNECTION

GoodWe EH series inverter complies with IEC 62109-2 13.9. Fault indicator LED on inverter cover will light up and the system will email the fault information to customer.

Inverter should be installed at eye level for convenient maintenance.

• WIRING SYSTEM FOR EH SERIES HYBRID INVERTER

Please select Breaker according to the specification below

	1	2	3	4	5
GW3600-EH	40A/600V DC breaker	50A/230V AC breaker	32A/230V AC breaker	Depends on household loads	
GW5000-EH	40A/600V DC breaker	63A/230V AC breaker	32A/230V AC breaker	Depends on household loads	
GW6000-EH	40A/600V DC breaker	63A/230V AC breaker	40A/230V AC breaker	Depends on household loads	

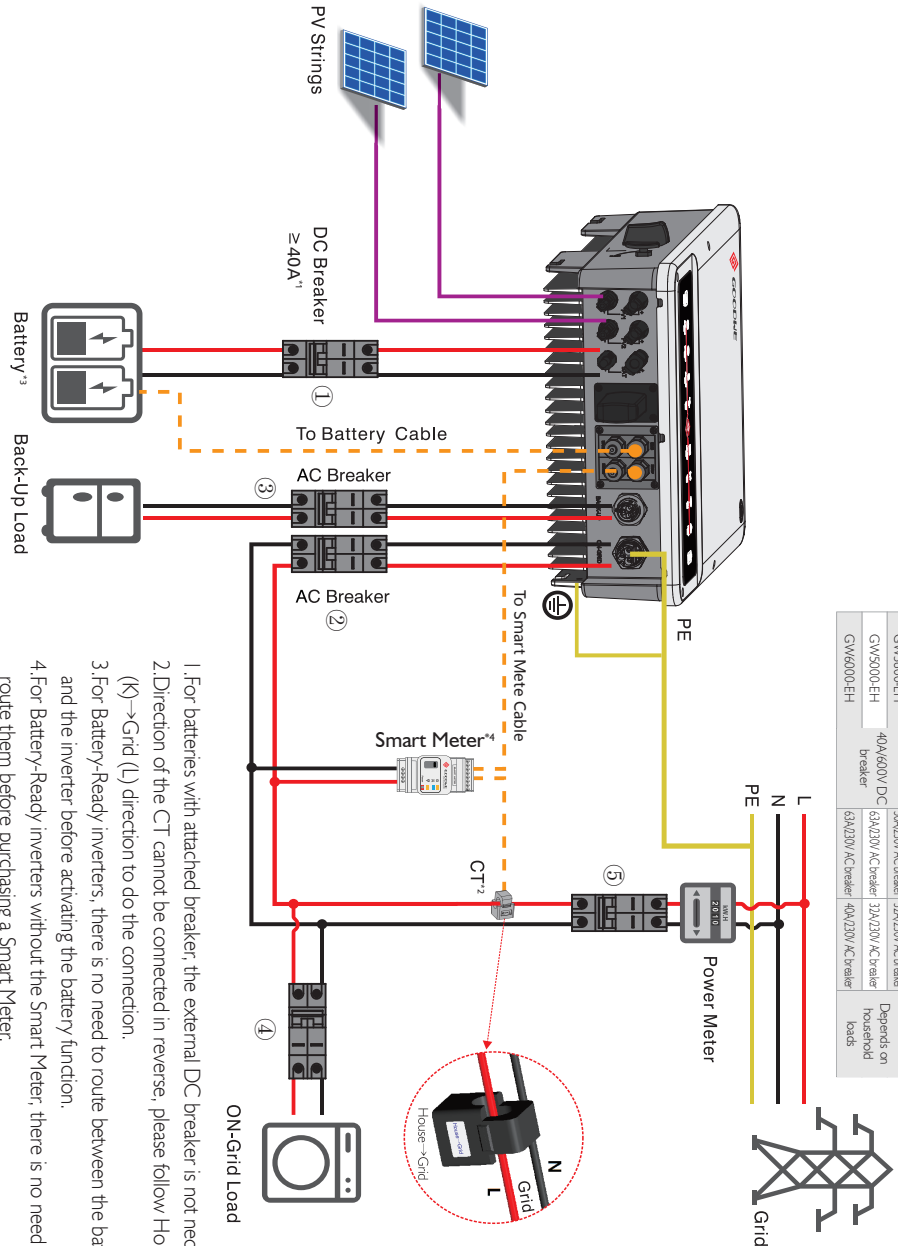

1. For batteries with attached breaker, the external DC breaker is not necessary.
2. Direction of the CT cannot be connected in reverse, please follow House (H) → Grid (L) direction to do the connection.
3. For Battery-Ready inverters, there is no need to route between the battery and the inverter before activating the battery function.
4. For Battery-Ready inverters without the Smart Meter, there is no need to route them before purchasing a Smart Meter.

System Connection Diagrams

Note: For Australia safety country, the neutral cable of On-Grid side and Back-Up side must be connected together, otherwise Back-Up function will not work.

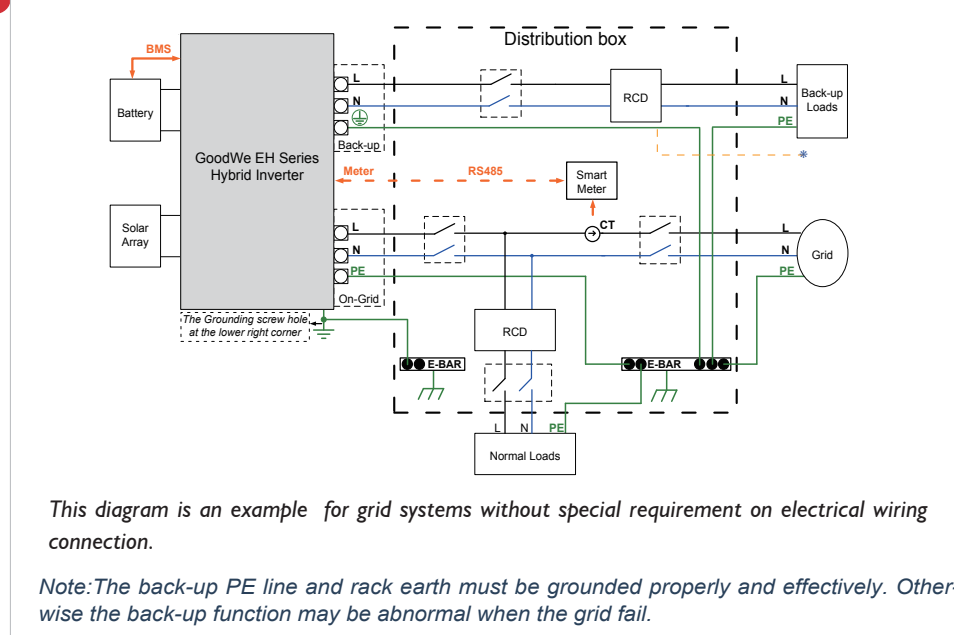
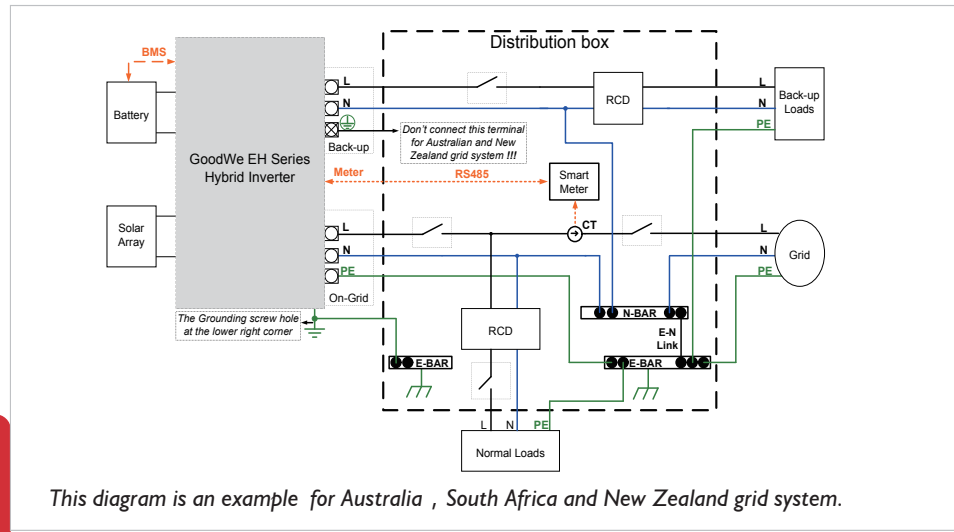

Note: After the inverter is installed and worked normal when the grid connected, please turn off the grid power to check whether the back-up function is normal, which can avoid the problems in subsequent uses.

03 MANUAL OPERATION

3.1 WIFI CONFIGURATION

- This part shows configuration on web page
- Wi-Fi configuration is absolutely necessary for online monitoring and after-sales maintenance

PREPARATION:

1. Inverter must be powered up with only PV power
2. Need a router with available internet access to GoodWe portal <https://www.semsportal.com>

Step 1

1. Connect Solar-WiFi* to your PC or smart phone>(* means the last 8 characters of the inverter serial No.)
2. Open browser and login 10.10.100.253
Admin (U): admin; Password: admin
3. Then click "OK"

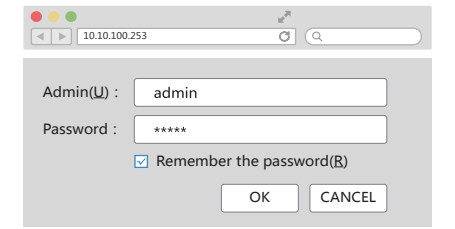

Step 2

1. Click "Start Setup" to choose your router
2. Then click "Next"

Device information	
Firmware version	1.6.9.3.38.2.1.38
MAC address	60:C5:A8:60:33:E1
Wireless AP mode	Enable
SSID	Solar-WiFi
IP address	10.10.100.253
Wireless STA mode	Disable
Router SSID	WiFi_Bum-in
Encryption method	WAP/WAP2-PSK
Encryption algorithm	AES
Router Password	WiFi_Bum-in

Cannot join the network, may be caused by:
router doesn't exist, or signal is too weak, or password is incorrect

★ Help: Wizard will help you to complete setting within one minute.

Start Setup

Please select your current wireless network:

SSID	Sec mode	Enc type	Channel	RSSI
WiFi Test	WAP2-PSK	AES	6	54%

★ Note: When RSSI of the selected WiFi Network is lower than 10%, the connection may be unstable, please select other available network or shorten the distance between the device and the router.
If your wireless router does not broadcast SSID, please click "Next" and add a wireless network manually.

Back **Next**

Step 3

1. Fill in the password of the router, then click "Next"
2. Click "Complete"

Add wireless network manually

Network name (SSID)	WiFi-Test
Encryption method	WPA/WPA2-PSK
Encryption algorithm	AES

Please enter the wireless network password:
Password (8-63 bytes)
show psk

Note: case sensitive for SSID and password
Please make sure all parameters of wireless network are matched with router, including password

Back **Next**

Save success!

Click 'Complete', the current configuration will take effect after restart.

If you still need to configure the other pages of information, please go to complete your required configuration.

Configuration is completed, you can log on the Management page to restart device by Click on 'OK' button.

Confirm to complete?

Back **Complete**

Note:

1. Please make sure the password, Encryption Method/Algorithm is right the same with the router's.
2. If everything is right well, the Wi-Fi LED on inverter will change from double blink to quartic blink then to solid status, which means Wi-Fi is connected to GoodWe icloud successfully.
3. Wi-Fi configuration could also be done on PV Master, details please check on PV Master APP.

• **Wi-Fi Reset & Reload**

Wi-Fi Reset means restarting Wi-Fi module, Wi-Fi settings will be reprocessed and saved automatically. Wi-Fi Reload means setting Wi-Fi module back to default factory setting.



Wi-Fi Reset

short press RESET button
– Wi-Fi Led will blink for a few seconds

Wi-Fi Reload

long press RESET button (longer than 3s)
– Wi-Fi Led on inverter will double blink until doing Wi-Fi configuration again.

Note: Wi-Fi Reset & Reload function is only used when:

1. Wi-Fi lost connection to internet or cannot connect to PV Master APP successfully.
2. Cannot find “Solar-WiFi signal” or have other Wi-Fi configuration problem.
3. Please do not use this button if Wi-Fi monitoring works well.

3.2 PV MASTER APP OPERATION

PV Master is an external monitoring/ configuration application for GoodWe hybrid inverters, used on smart phones or pad for both Android and iOS system, main functions as below:

1. Edit system configuration to make the system work as customer needs.
2. Monitor and check performance of the hybrid system.
3. Wi-Fi configuration.

Please download PV Master OPERATION INSTRUCTIONS from www.goodwe.com



3.3 CEI AUTO-TEST FUNCTION

PV Auto-Test function of CEI is integrated in PV Master APP for Italy safety country requirement. For detailed instruction of this function please refer to PV Master Operation Instructions.

3.4 BATTERY FUNCTION ACTIVATION

If your inverter is Battery-Ready and you want to activate the battery function, you need to contact the dealer to purchase an activation code and activate the battery function in PV MASTER.

In the Advanced Setting, click on Set, enter the activation code, then go to the Basic Setting to select the work mode, battery model and test the meter, your inverter can be used as a hybrid inverter.

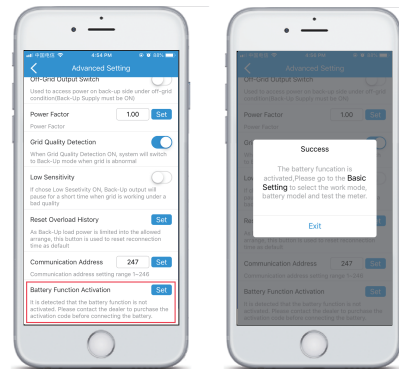

04 OTHERS

4.1 DISCLAIMER

The EH series hybrid inverters are transported, used and operated under environmental and electrical conditions. GoodWe has the right not providing after-sales services or assistance under following conditions:

- Inverter is damaged during transferring.
- Inverter is out of warranty year and extended warranty is not bought.
- Inverter is installed, refitted or operated in improper ways without authority from GoodWe.
- Inverter is installed or used under improper environment or technical condition mentioned in this user manual, without authority from GoodWe.
- Installation or configuration of the inverter does not follow requirements mentioned in this user manual.
- The inverter is installed or operated against the requirements or warnings that are mentioned in this user manual.
- Inverter is broken or damaged by any force majeure like lightning, earthquake, fire hazard, storm and volcanic eruption etc.
- Inverter is disassembled, changed or updated on software or hardware without authority from GoodWe.
- Inverter is installed, used or operated against any related items in international or local policies or regulations.
- Any non-compatible batteries, loads or other devices connected to EH system.
- Obtain the Battery-Ready inverter activation code through illegal channels.

Note:

GoodWe will keep right to explain all the contents in this user manual. To insure IP65, inverter must be sealed well, please install the inverters in one day after unpacking, otherwise please seal all unused terminals/holes, not allowed to keep any terminals/holes open, confirm there is no risk to have water & dust in.

*** Maintenance**

The inverter requires periodically maintenance, details as below:

- Make sure inverter is totally isolated from all DC and AC power for at least 5 mins before maintenance.
- Heat sink: Please use clean towel to clean up heat sink once a year.
- Torque: Please use torque wrench to tighten AC and DC wiring connection once a year.
- DC breaker: Check DC breaker regularly, active the DC breaker 10 times in a row once a year.
- Operating DC breaker will clean contacts and extend lifespan of DC breaker.
- Water-proof covers: Check if water-proof covers of RS485 and other part are fastend once a year.

4.2 ERROR MESSAGE AND TROUBLESHOOTINGS

• ERROR MESSAGE

The error message below will be displayed on PV Master APP or reported by Email if the error really happens.

ERROR MESSAGE	EXPLANATION	REASON	SOLUTIONS
Utility Loss	Not available of public grid power (power lost or on-grid connection fails)	Inverter does not detect the connection of grid	<ol style="list-style-type: none"> 1. Check (use multi-meter) if AC side has voltage , Make sure grid power is available 2. Make sure AC cables are connected tightly and right well 3. If all is well, please try to turn off AC breaker and turn on again after 5 mins
VAC Failure	Grid voltage is not within permissible range	Inverter detects that AC voltage is beyond the normal range required by the safety country	<ol style="list-style-type: none"> 1. Make sure safety country of the inverter is set right 2. Check (use multi-meter) if AC voltage (Between L&N or L&L) is within a normal range (Also on AC breaker side) <ol style="list-style-type: none"> a. if AC voltage is high, then make sure AC cable complies with that required on user manual and AC cable is not too long b. if voltage is low, make sure AC cable is connected well and the jacket of AC cable is not compressed into AC terminal 3. Make sure the grid voltage of your area is stable and within normal range.
FAC Failure	Grid Efficiency is not within permissible range	Inverter detects that Grid frequency is beyond the normal range required by the safety country	<ol style="list-style-type: none"> 1. Make sure safety country of the inverter is set right 2. If safety country is right, then please check on inverter APP if AC frequency (Fac) is within a normal range 3. If FAC failure only appear a few times and resolved soon, it should be caused by occasional grid frequency instability.
PV/BAT Over Vlotage	PV or BAT voltage is too high	The total voltage (open -circuit voltage) of each PV string is higher than the max DC input voltage of the inverter. Or the battery voltage is higher than the max BAT input voltage of the inverter	<p>Check PV string VOC is lower than Max PV Input Voltage of the inverter</p> <p>If VOC of PV string is high, please decrease panels to make sure VOC is with the max DC input voltage of the inverter.</p>
Over Temperature	Temperature inside of the inverter is too high	Inverter working environment leads to a high temperature condition	<ol style="list-style-type: none"> 1. Try to decrease surrounding temperature 2. Make sure the installation complies with the instruction on inverter user manual 3. Try to close inverter for 15 mins, then start up again.
Isolation Failure	Ground insulation impedance of PV string is too low	Isolation failure could be caused by multi reasons like PV panels are not grounded well, DC cable is broken, PV panels are aged or surrounding humidity is comparatively heavy, etc.	<ol style="list-style-type: none"> 1. Use multi meter to check if the resistance between earth & inverter frame is about zero. If it's not, Please make the connection between earth & inverter frame well. 2. If the humidity is very high, there maybe Isolation Failure occur. 3. Check the resistance between PVI +/PV2 +/BAT +/PV- to earth, if the resistance is lower than 33.3k, check the system wiring connection. 4. Try to restart the inverter, check if the fault is still happens, if not, means it is just an occasional situation, or contact GoodWe.
Ground I Failure	Ground leakage current is over-high	Ground I failure could be caused by multi reasons like neutral cable on AC side is not connected well or surrounding humidity is comparatively heavy, etc.	<p>Check use multi-meter if there is voltage value (normally should be close to 0V) between earth & inverter frame.</p> <p>If there is a voltage, it means the Neutral & ground cable are not connected well on AC side. If it happened only at early morning, dawn or on rainy days with high air humidity, and recover soon, it should be normal</p>
Relay Check Failure	Self checking of relay fails	Neutral & ground cable are not connected well on AC side or just occasional failure	<p>Check use multi-meter if there is high voltage (normally should be lower than 10V) between N&PE cable on AC side.</p> <p>If the voltage higher than 10V, it means the Neutral & ground cable are not connected well on AC side or restart inverter.</p>
DC Injection High	/	Inverter detects a higher DC component in AC output	Try to restart inverter, check if it still happens, if not, means it is just an occasional situation or contact GoodWe
EEPROM RW Failure	/	Caused by a strong external magnetic field etc.	Try to restart inverter, check if it still happens, if not, means it is just an occasional situation or contact GoodWe
SPI Failure	Internal communication fails	Caused by a strong external magnetic field etc.	Try to restart inverter, check if it still happens, if not, means it is just an occasional situation or contact GoodWe
DC Bus High	BUS voltage is over-high	/	Try to restart inverter, check if it still happens, if not, means it is just an occasional situation or contact GoodWe
Back-Up Over Load	Back-up sid is over loaded	Total Back-Up load power is higher than the nominal backup output power	Decrease Back-Up loads to make sure the total load power is lower than Back-Up nominal output power (please refer to page 12)
Battery License Fault	Battery function is not activated	Connect the battery to the inverter without the battery function activated	First purchase the activation code and activate the battery function in PV MASTER, then connect the battery to use.

• TROUBLESHOOTINGS

Checking Before Turning On AC power

- ✦ **Battery Connection:** Confirm the connection between EH and battery : polarity (+/-) not reversed, refer to Pic 33
- ✦ **PV Input Connection:** Confirm the connection between EH and PV panels : polarity (+/-) not reversed, refer to Pic 34
- ✦ **On-Grid & Back-Up Connection:** Confirm ON-GRID connected to power grid and Back-up to loads : polarity (L/N are in sequence) not reversed, refer to Pic 35
- ✦ **Smart Meter & CT Connection:** Make sure Meter & CT are connected between house loads and grid, and follow the Smart Meter direction sign on CT, refer to Pic 36

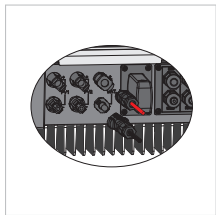

Pic 33

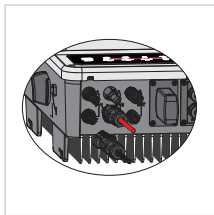

Pic 34

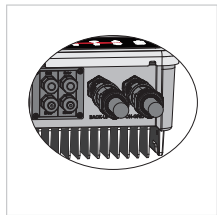

Pic 35

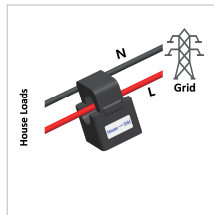

Pic 36

Checking as Start EH up and Turn On AC Power

- ✦ **Battery Settings, BMS Communication and Safety Country:** After connecting Solar-WiFi* (* means the last 8 characters of the inverter serial No.), check on PV Master APP Param to make sure battery type is right what you have installed, and Safety Country is right. If not right, please set it right in "Set" (Pic 32)

Note:
For compatible lithium batteries, BMS status is "Communication OK" after selecting the right battery type.

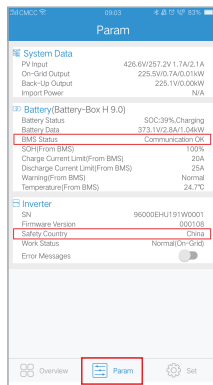

Pic 36

Possible Problems During Operation

No Discharge or Output From EH at Night Without PV or PV Power Lower Than Load Power:

Solution:

1. Communication between EH and Smart meter is OK or not;
2. Make sure load power is higher than 100W
 - a. Battery will not discharge continuously unless load power is higher than 100W;
 - b. If battery still not discharge when Meter power is higher than 100W, then please check Meter & CT connection and direction;
3. Make sure SOC is higher than 1-DOD. Or if battery discharged to below 1-DOD, than battery will only discharge again when SOC charged to (20%+ 1-DOD) /2 and SOC > 105% -DOD (if need battery discharge immediately, Inverter should be restarted)
4. Check on APP if it is set as charge time, during charge time, battery will not discharge (battery will charge in priority during coincident time of charge/discharge)

Battery Not Charge When PV Power Higher Than Load Power:

Solution:

1. Check if it is during discharge time set on App.
2. Check if battery is fully charged or not, or battery voltage reach "charge voltage" or not.

High Power Fluctuation on Battery Charge or Discharge:

Solution:

1. Check if there is a fluctuation on load power;
2. Check if there is a fluctuation on PV power.

Battery Does Not Charge

Solution:

1. Make sure BMS communication is OK on PV Master (for lithium batteries);
2. Check if CT connected in the right position and to right direction as on the user manual page 15 ;
3. Check if the total load power is much higher than PV power.

Questions & Answers (Q & A)

About Wi-Fi Configuration

Q: Why cannot connect Solar-Wifi signal on my phone?

A: It is the character of the Wi-Fi module that it can connect to only one device at a time. If the signal is connected to another device at the time for some reason, then you cannot connect to the signal.

About Battery Operation

Q: Why battery does not discharge when grid is not available, while it discharge normally when grid is available?

A: On APP, Off-Grid Output and backup function should be turned on to make battery discharge under off-grid mode.

Q: Why there is no output on Back-Up side?

A: For Back-Up supply, the "Back-Up Supply" on PV Master App must be turned on. Under off-grid mode or grid power is disconnected, "Off-Grid Output Switch" function must be turned on as well

Note: As turn " Off-Grid Output Switch " on, don't restart inverter or battery, otherwise the function will switch off automatically.

Q: On Portal, why battery SOC has a sudden jump up to 95%?

A: This normally happens on when BMS communication fail on lithium battery. If battery enter float charge, SOC will be reset to 95% compulsively.

Q: Why battery cannot be fully charged to 100%

A: Battery will stop charge when battery voltage reaches charge voltage set on PV Master APP

Q: Why battery switch always trip when starts it up (Lithium battery)?

A: The switch of lithium battery normally trips for following reasons:

1. BMS communication fails.
2. Battery SOC is too low, battery trips to protect itself.
3. An electrical short-cut happened on battery connection side. Or other reasons please contact GoodWe for details.

Q: Which battery should I use for EH?

A: For EH series inverter, it could connect Lithium batteries which have compatibility with EH series inverter. With nominal voltage from 85V to 450V.
Compatible lithium batteries can see on battery list in PV MASTER APP

About PV Master Operation and Monitoring

Q: Why Cannot save settings on PV Master App

A: This could be caused by losing connection to Solar-WiFi.

1. Make sure you connected Solar-WiFi (make sure no other devices connected) or router (if connected Solar-WiFi to router) and on APP home page shows connection well.
2. Make sure EH under waiting mode (on APP) before you change any settings on PV Master APP — disconnect grid/load/battery, only leave PV connected and then restart EH till see work mode as "wait" on APP.

Q: On the App, why the data on the homepage and Param page is different, like charge/discharge, PV value, load value or grid value?

A: As the data on APP is from inverter and on home page and Param page, the data refresh frequency is different, so there will be a data inconformity between different pages on APP as well as between that on portal and APP

Q: On App, some columns show NA, like battery SOH, etc. why is that?

A: NA means App does not receive data from inverter or server, normally it is because communication problem, such as battery communication, and communication between inverter and the APP.

About Meter and Power Limit Function

Q: How to Act Output Power Limit function?

A: For EH system, the function could be realized by:

1. Make sure Meter connection and communication well;
 2. Turn on Export Power Limit function and Set the max output power to grid on APP;
- Note: If Out-put Power Limit set as 0W, then there might still have deviation max 100W exporting to grid.*

Q: Why there is still power exporting to grid after I set power limit as 0W?

A: Export limit could theoretically to minimum 0W, but there will have a deviation of around 50-100W for EH system.

Q: Can I use other brand Meter to take over Meter in EH system or change some settings on Meter?

A: Cannot, because there the communication protocol is inset between inverter and Meter, other brand Meter cannot communicate. Also any manual setting change could cause Meter communication failure.

Q: What is the max current allowed going through CT on Meter?

A: The max current for CT is 120A

Other Questions

Q: Is there a quick way to make the system work?

A: The shortest way, please refer to EH QUICK INSTALLATION INSTRUCTIONS and PV MASTER APP INSTRUCTION

Q: What kind of load can I connect on Back-Up side?

A: Please refer to user manual on page 12

Q: Whether the warranty of the inverter still valid if the installation or operation does not follow the user manual instructions, for some special conditions when we cannot 100% follow them?

A: Normally if any problem caused by disobey the instructions on user manual, we can provide technical support to help to solve the problem, but cannot guarantee a replacement or returns. So if there is any special condition when you cannot 100% follow the instructions, please contact GoodWe for suggestions.

4.3 TECHNICAL PARAMETERS AND CERTIFICATES

• TECHNICAL PARAMETERS OF EH INVERTER

Technical Data	GW6000-EH	GW5000-EH	GW3600-EH
Battery Input Data			
Battery Type		Li-Ion	
Battery Voltage Range(V)		85~450	
Start-up Voltage (V)		90	
Max. Charging/Discharging Current (A)		25/25	
Max. Charging/Discharging Power (W)	6000	5000	3600
PV String Input Data			
Max. DC Input Power (W)	8000	6650	4800
Max. DC Input Voltage (V)	580	580	580
MPPT Range (V)	100~550	100~550	100~550
Start-up Voltage (V)	90	90	90
MPPT Range for Full Load (V)	250~550	210~550	150~550
Nominal DC Input Voltage (V)	380	380	380
Max. Input Current (A)		12.5/12.5	
Max. Short Current (A)		15.2/15.2	
PV Overcurrent Protection (A)	21/21	21/21	21/21
The backfeed current to the array (A)	0	0	0
No. of MPP Trackers		2	
No. of Strings per MPP Tracker		1	
AC Output/Input Data (On-grid)			
Nominal Apparent Power Output to Utility Grid (VA)	4600/5000/6000[1]	4600/5000[2]	3600
Max. Apparent Power Output to Utility Grid(VA)	4600/5000/6000/6600[3]	4600/5000/5500[4]	3600/3960[5]
Max. Apparent Power from Utility Grid (VA)	12000(Charging 6kW, backup output 6kW)	10000(Charging 5kW, backup output 5kW)	7200(Charging 3.6kW, backup output 3.6kW)
Nominal Output Voltage (V)		230	
Nominal Output Frequency (Hz)		50/60	
Max. AC Current Output to Utility Grid (A)	21.7[6]/26.1/28.7[7]	21.7/24.0[8]	16/18.0[9]
Max. AC Current From Utility Grid (A)	52.2	43.4	32
The Maximum Output Fault Current (peak/duration)	65A, 5μs	65A, 5μs	65A, 5μs
Input Inrush Current (Peak/Duration)	65A, 5μs	65A, 5μs	65A, 5μs
Maximum Output RMS Overcurrent Protection (A)	26.1	21.7	16
AC Backfeed Current@Standby mode (A)	0	0	0
Output Power Factor	Adjustable from 0.8 leading to 0.8 lagging		
Output THDi (@Nominal Output)	<3%		
Back-up Output Data (UPS)			
Max. Output Apparent Power (VA)(@Linear Load)	6000	5000	3600
Peak Output Apparent Power (VA)*	7200, 60sec	6000, 60sec	4320, 60sec
Max. Output Current (A)(@Linear Load)	26.1	21.7	15.7
Automatic Switch Time (ms)	<10		
Nominal Output Voltage (V) (@Linear Load)	230 (±2%),single phase		

Technical Data	GW6000-EH	GW5000-EH	GW3600-EH
Back-up Output Data (UPS)			
Nominal Output Frequency (Hz)(@Linear Load)	50/60 (±0.2%)		
Output inrush Current (peak/duration)	65A, 5μs		
Maximum output RMS overcurrent protection (A)	31	26	19
Back-Up Over Current Protection (A)	65		
Output THDv (@Linear Load)	<3%		
Efficiency			
PV Max. Efficiency	97.6%		
PV Europe Efficiency	97%		
Battery Charged By PV Max. Efficiency	98%		
Battery Charge/discharge From/To AC Max. Efficiency	96.6%		
Protection			
Anti-islanding Protection	Integrated		
Battery Input Reverse Polarity Protection	Integrated		
Insulation Resistor Detection	Integrated		
Residual Current Monitoring Unit	Integrated		
Output Over Current Protection	Integrated		
Grid Output Short Protection	Integrated		
Output Over Voltage Protection	Integrated		
General Data			
Operating Temperature Range (°C)	-35~60		
Relative Humidity	0~95%		
Environment Category	Outdoor & indoor		
External Environment Pollution Degree	Grade I、2、3		
Protective class	Class I		
Over voltage category	DC II: ACIII		
Operating Altitude (m)	4000		
Cooling	Nature Convection		
Noise (dB)	<35		
User Interface	LED & APP		
Communication with BMS	CAN		
Communication with Meter	RS485		
Communication with Portal	Wi-Fi/Ethernet		
Weight (kg)	17		
Size (Width*Height*Depth mm)	354*433*147		
Mounting	Wall Bracket		
Protection Degree	IP65		
Standby Self Consumption (W)**	<10		
Topology	Transformerless		

Technical Data	GW6000-EH	GW5000-EH	GW3600-EH
Certifications & Standards			
Nominal Output Frequency (Hz) (@Linear Load)	AS/NZS 4777.2:2015; G99/1; CEI 0-21 VDE4105-AR-N		
Safety Regulation	IEC/EN62109-1&2		
EMC	EN61000-6-1,EN61000-6-2 EN61000-6-3,EN61000-6-4 EN 61000-4-16, EN 61000-4-18, EN 61000-4-29		

*Can be reached only if PV and battery power is enough

**No Back-up Output

[1] 4600 for VDE-AR-N 4105, 5000 for Australia, 6000 for other country.

[2] 4600 for VDE-AR-N 4105, 5000 for other country.

[3] 4600 for VDE-AR-N 4105, 5000 for Australia, 6600 for Italy, 6000 for other country.

[4] 4600 for VDE-AR-N 4105, 5500 for Italy, 5000 for other country.

[5] 3960 for Italy, 3600VA for other countries.

[6] 21.7 for Australia.

[7] [8][9] for Italy.

• CERTIFICATES OF ET SERIES



G100 IEC62109-1 CEI 0-21
RD1699 VDE0126-1-1 VDE-AR-N 4105 NRS 097-2-1

• OTHER TEST

For Australia requirements, in the THDi test, there should add Zref between inverter and mains.

RA , XA for Line conductor

RN, XN for Neutral conductor

Zref:

RA=0,24;XA=j0,15 at 50Hz;

RN=0,16;XN=j0,10 at 50Hz.

4.4 WARNING QUICK CHECK LIST

[1] Inverter cannot be installed near flammable, explosive or strong electro-magnetic equipment, page 06

[2] Remember that this inverter is heavy! Please be careful when lifting out from the package, page 07

[3] The polarity of PV strings or on the inverter cannot be connected by reversely, otherwise inverter could be damaged, page 08

[4] Make sure battery breaker is off and battery nominal voltage meet EH specification before connecting battery to inverter and make sure inverter is totally isolated from PV and AC power, page 09

[5] Make sure inverter is totally isolated from any DC or AC power before connecting AC cable, page 11

[6] Make sure AC cable is totally isolated from AC power before connecting Smart Meter & CT, page 13

Appendix: Protection Category Definition

Overvoltage Category Definition

Category I	Applies to equipment connected to a circuit where measures have been taken to reduce transient overvoltage to a low level
Category II	Applies to equipment not permanently connected to the installation. Examples are appliances, portables tools and other plug-connected equipment
Category III	Applies to a fixed equipment downstream of and including the main distribution board. Examples are switchgear and other equipment in an industrial installation
Category IV	Applies to equipment permanently connected at the origin of an installation (upstream of the main distribution board). Example are electricity meters, primary over-current protection equipment and other equipment connected directly to outdoor open lines

Moisture Location Category Definition

Moisture Parameters	Level		
	3K3	4K2	4K4H
Temperature Range	0~+40 C	-33~+40 C	-20~+55 C
Humidity Range	5%~85%	15%~100%	4%~100%

Environment Category Definition

Environment Condition	Ambient Temperature	Relative Humidity	Applied to
Outdoor	-20 ~ 50 C	4% ~ 100%	PD3
Indoor Unconditioned	-20 ~ 50 C	5% ~ 95%	PD3
Indoor Conditioned	0 ~ 40 C	5% ~ 85%	PD2

Pollution Degree Definition

Pollution Degree I	No pollution or only dry, non-conductive pollution occurs. The pollution has no influence
Pollution Degree II	Normally only non-conductive pollution occurs. Occasionally, however, a temporary conductivity caused by condensation must be expected.
Pollution Degree III	Conductive pollution occurs, or dry, non-conductive pollution occurs, which becomes conductive due to condensation, which is expected.
Pollution Degree IV	Persistent conductive pollution occurs, for example, the pollution caused by conductive dust, rain and snow.

4.5 CHECKING THE ELECTRICAL CONNECTION

1. Check if the AC or DC wire is loose.
2. Check if the earth wire is reliable grounding.
3. Check if the waterproof covers of BMS and Meter port is fasten.
4. Please use torque wrench to tighten the AC and battery terminal wiring connection once a year; followed 2.4 torque instruction.

Caution: Maintenance cycle is once half a year.